

Specification MAP/CV46/Issue 4. Dated 14.1.49 To be read in conjunction with K1001, ignoring clauses:- 5.2, 5.8, 7.2.	<u>SECURITY</u>	
	<u>Specification</u> RESTRICTED	<u>Valve</u> UNCLASSIFIED

→ Indicates a change

<u>TYPE OF VALVE</u> - Triode <u>CATHODE</u> - Directly heated thoriated tungsten <u>ENVELOPE</u> - Metal - glass construction.	<u>MARKING</u> See K1001/4.	
	<u>PACKING</u> See K1005	
	<u>BASE</u> None	
<u>RATING</u>	Note	<u>DIMENSIONS</u> See Page 3.
Filament Voltage (V) 8.25 Filament Current (A) 7.0 Maximum Anode Voltage (kV) 2.0 Maximum Anode Dissipation (W) 150 Amplification factor 15.5 Anode Impedance (Ω) 5000 Max. Operation Frequency (Mc/s) 100	B A A	
<u>CAPACITANCES</u>		
Anode to grid (pF) 3.75 Grid to filament (pF) 2.2 Anode to filament (pF) 0.9		

NOTES

- A: At $V_a = 1.0$ kV, $I_a = 100$ mA
- B: Forced air cooling must be provided so that the temperature of the anode radiator does not exceed 140°C measured at the junction of the anode and the cooling fins. A suitable air flow is approximately 15 cu.ft. per minute with a pressure drop across the valve of the order of $\frac{1}{2}$ inches of water. Forced air cooling must be applied before the filament is switched on.
- C: The valve must be mounted vertically.
- D: The attention of equipment designers is drawn to the fragility of the valve seals, and consequently special care should be exercised in the mechanical design of associated circuits.

To be performed in addition to those applicable in K1001.

Test Conditions					Test	Limits		No. Tested
						Min.	Max.	
For the following tests forced air cooling shall be provided so that the temperature of the anode radiator shall not exceed 140°C. measured at the junction of the anode and the cooling fins. A suitable air flow is approx. 15 cu.ft. per minute with a pressure drop across the valve of the order of 1½ inches of water.								
a	Vf	Va	Vg	Ia(mA)	If (A)	6.4	7.6	100%
	8.25 A.C.	0	0	-				
b	8.25 A.C.	1500	-	100	Reverse Ig (µA)	-	10	100%
	Maintained for 5 minutes.				The last 3 one minute readings to be steady.			
c	8.25 A.C.	1000	-	100	-Vg1 (V)	19	29	100%
d	8.25 A.C.	700	-	100	Vg change from value obtained in test (c) (V)	14	22	1% (1)
e	8.25 A.C.	Strapped. Peak applied voltage 1500V. Test to be performed by an approved method.		-	Ie (A)	5	-	100%
f	8.25 A.C.	-	-104	4	Va (V)	1325	1700	100%
g	To be measured using Adaptor Type 100. Ref. 10A/17529. See K1001/AIII				<u>CAPACITANCES</u>			6 per week
	Links to H.P.	Links to L.P.	Links to E					
	2	3	1,4,5,6,7,8,9,10 TC1, TC2	Cag (pF)				
	3	1	2,4,5,6,7,8,9,10 TC1, TC2	Cgf (pF)				

THE SEALING PIP SHALL NOT PROJECT BEYOND THE ANODE RADIATOR.

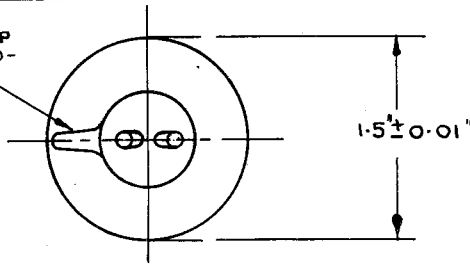

CORONA RING, 1³/₁₆" TUBE, 1" BORE. TOLERANCES ACCORDING TO BSS.885 AND BSS.886 FOR COMMERCIAL TUBING.

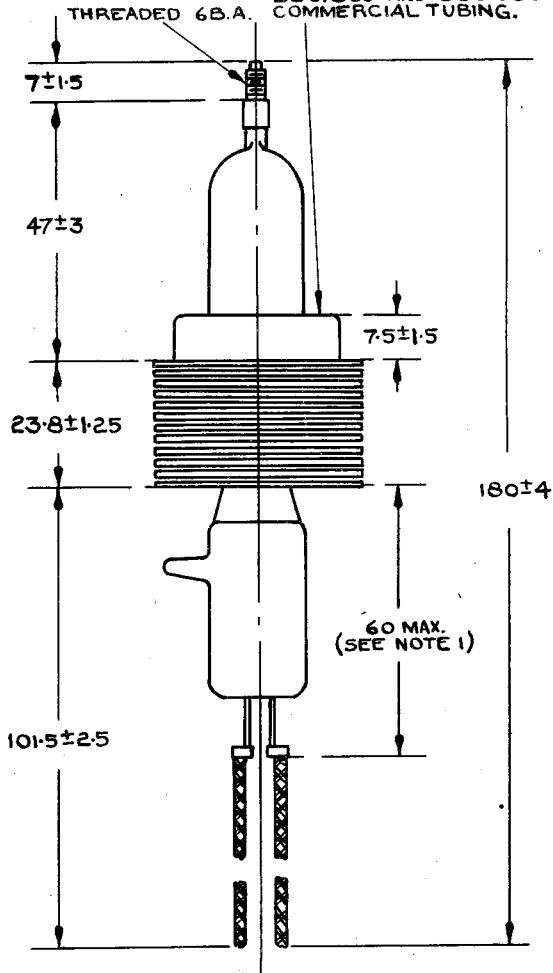

ALL DIMENSIONS IN MILLIMETRES UNLESS OTHERWISE STATED.

NOTE 1. THIS DIMENSION SHALL INCLUDE ANY RIGIDITY OF THE FILAMENT LEADS DUE TO THE SPREAD OF SOLDER FROM THE CONNECTIONS WITH THE TUNGSTEN LEAD OUT WIRES.