

Tunk-Horn

Video Service

JVC

No. 8074

SERVICE MANUAL

PORTABLE VIDEO CAMERA

MODEL GS-4600E



..... **VICTOR COMPANY OF JAPAN, LIMITED**

INTRODUCTION

This service manual provides service information for the JVC Black and White Portable Video Camera Model GS-4600E.

The GS-4600E is simple to operate either outdoors or in a studio. It provides clear and sharp pictures, weighing only 1.85kg complete with handgrip. It can be used with the Black and White Portable Video Tape Recorder PV-4500, the Colour Portable Video Tape Recorder PV-4800E or the Colour Video Cassette Recorder CR-6000E using the Colour Camera Adaptor GA-20E.

SPECIFICATIONS

Scanning system	: 625 lines, 25 frames, 2:1 interlace (driven by PV-4500, PV-4800E or GA-20E)
Vidicon tube	: 2/3" electrostatic focus/electromagnetic deflection
S/N ratio	: Better than 43db at 6,000 lux, F4
Horizontal resolution	: More than 450 lines at center
Horizontal frequency	: 15.625kHz
Vertical frequency	: 50Hz
Video output	: 1Vp-p (75 ohms unbalanced), sync negative (at the input of the PV-4500, PV-4800E or GA-20E)
Audio output	: -20db (at the PV-4500, PV-4800E or GA-20E) High impedance
Minimum illumination	: 20 lux
Automatic light compensation	: 50-100,000 lux
Built-in microphone	: -68db/1,000 ohms, electret condenser microphone (switchable between uni-directional and omni-directional)
Zoom lens	: F1.8, f=12.5-75mm, 6X
Viewfinder	: 1.5" electronic viewfinder. Record, stand-by and playback picture monitoring available
Start/stop switch	: Built into camera body and handgrip (trigger)
Tally lamp	: Built-in (Light Emitting Diode)
Recording lamp	: Light Emitting Diode (Also acts as a battery power warning lamp)
Operating temperature	: -10°C to +45°C
Power requirements	: 12V DC, 7.2W
Dimensions	: 235 ^m /m(H) x 77 ^m /m(W) x 325 ^m /m(D) including lens hood and handgrip
Weight	: 1.85kg (with handgrip and zoom lens)

FEATURES

- A 2/3" high sensitivity electrostatic focus/electromagnetic deflection vidicon tube ensures high quality pictures and easy operation while the camera is lightweight and compact.
- Simultaneous sound recording is possible with the built-in condenser microphone which is switchable between uni-directional/omni-directional.
- Super-compact electronic viewfinder lets you view the playback pictures for the on-the-spot checking.
- The built-in 6X zoom lens lets you zoom effectively from wide-angle to telephoto or vice versa.
- Lamps on the front of the camera and in the viewfinder light to inform the actors and the cameraman that the connected VTR is recording.
- The lamp in the viewfinder flickers when the battery power becomes low.

PRECAUTIONS

1. Do not point the camera at extremely bright objects such as the sun or its reflected light as this will damage the vidicon tube.
2. The vidicon tube will deteriorate with age. When the camera is not in use, switch off the power, close the lens aperture and replace the lens cap.
3. When using the camera after storage for a long time, wait for a while after switching on the power before operating.
4. A special protector is needed when using the camera outdoors, or in special environments, at extremely high or low temperatures or in extremely humid places, for example.
5. Using the camera near TV or radio transmitting antennas, fluorescent lights, motors, or TV receivers will cause unstable images or fringe interference.

NAME OF MAIN COMPONENTS AND CONTROLS

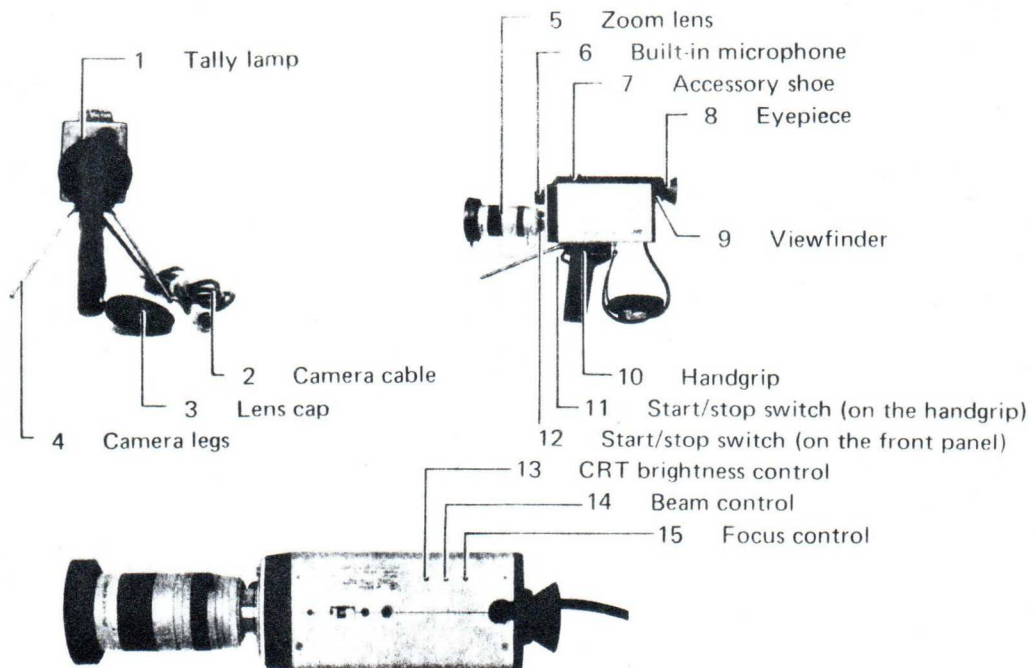

1. Tally lamp
Glows red when the VTR starts recording.
2. Camera cable
Connect to the PV-4500 , PV-4800E or GA-20E camera terminal.
3. Lens cap
Always cap the lens when camera is not in use. If you fail to do so with the aperture open, the vidicon tube may be damaged.
4. Camera legs
Camera can be set up on a table or desk for easier visibility. Useful when the viewfinder is used as an indoor playback.
5. Zoom lens
F1.8 to close, f=12.5–75mm, 6X C-mount.
 - 1) Aperture ring: Automatic light level control is provided; the use of this aperture ring will help enhance the quality of pictures.
Desirable aperture setting are as follows:
Indoors, dark morning/evening – F1.8 to 4
Rainy day, bright morning/evening – F4 to 5.6
In shadows, cloudy day – F5.6 to 8
Fine day outdoors – F8 to 16.
When not in use – "C" (closed)
 - 2) Zoom ring: Varies the size of image, i.e. angle of view.
 - 3) Focus ring: When focusing, set the zoom ring to maximum telephoto; and then turn the focus ring to focus the lens.
Once focused the correct focus will always be maintained throughout the entire zoom range.
6. Built-in microphone
High sensitivity condenser microphone. Pull for uni-direction and push for omni-direction.
7. Accessory shoe
Slide lighting equipment into this when the subject is insufficiently illuminated.
8. Eyepiece
Prevents light from entering the viewfinder when recording outdoors. Flip it up when shooting indoors, or when using the viewfinder as a playback monitor.
9. Viewfinder
For monitoring the scenes being recorded and for viewing the playback pictures after recording.
10. Handgrip
For hand-held operation of the camera.
11. Start/stop switch (on the handgrip)
Push to start recording or playback with the VTR.
12. Start/stop switch (on the front panel)
This switch functions in the same way as the start/stop switch on the handgrip. Use it when the camera is mounted on the tripod.
13. CRT brightness control
Turn the brightness control VR so that the viewfinder brightness is suitable.
14. Beam control for the vidicon
Adjust the control VR when beam of the vidicon goes down.
15. Electric focus control for the vidicon
Adjust this control VR when you have a chance to make vidicon alignment.

OPERATION

1. Recording in black and white with JVC B/W Portable Video Tape Recorder PV-4500, or with JVC Colour Portable Video Tape Recorder PV-4800E.

Preparations

- (1) Remove the lens mount cap and camera cap and mount the zoom lens by screwing it in clockwise. Make sure that the start/stop switch on the front of the camera is in its out position.

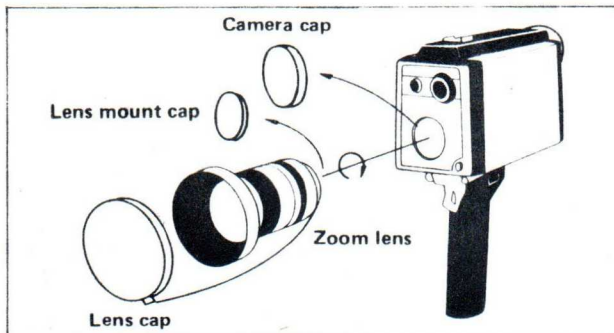

NOTE: The ring at the end of the zoom lens is to hold the lens cap. When mounting the zoom lens, do not remove this ring.

- (2) Connect the camera cable to the TV-CAMERA 10-pin connector of the VTR.

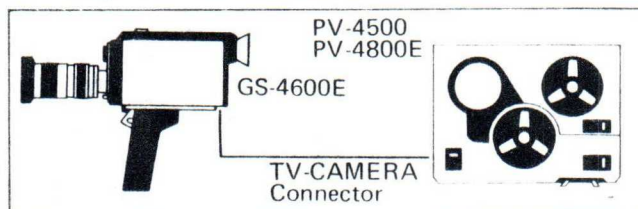

- (3) Make sure that the battery pack in the PV-4800E (PV-4500) is fully charged or that the AC Power Adapter AA-P40E (ACP-22K) VTR-BATT switch is set to the VTR mode.
- (4) Load a tape correctly.
- (5) Set the VTR TV-CAMERA switch to CAMERA.
- (6) Set the PV-4800E MODE selector to B/W. At COLOUR or DUB position, normal pictures may not be obtained.

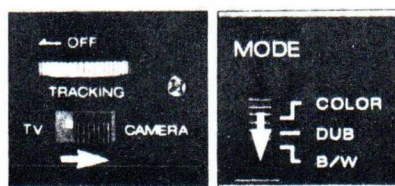

Recording

- (1) Place the PV-4800E (PV-4500) in the recording mode in order to put the camera in the stand-by condition. After 10 to 20 seconds the viewfinder will become bright.

NOTE: If the tally and recording lamps of the camera light after the VTR is set in the recording mode, push the start/stop switch on the handgrip immediately.

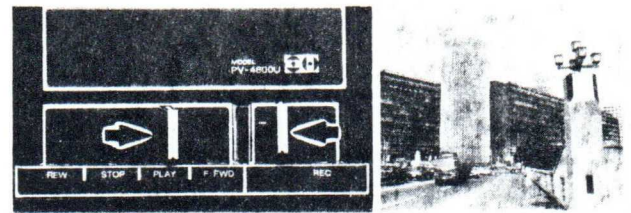

- (2) Remove the lens cap and open the aperture. The subject will now be seen in the viewfinder.
- (3) Turn the zoom ring to achieve the desired composition and adjust the focus.
- (4) Push the start/stop switch on the handgrip. The picture seen in the viewfinder and the sound picked up by the built-in microphone will be recorded on the VTR.

NOTES: ● During recording, the red lamps in the viewfinder and on the front of the camera will light.
● If the lamp in the viewfinder begins to flicker, it means that the battery should be replaced soon. The battery must be replaced when the lamp flickers continuously.

To stop recording and start playback

- (1) Press the start/stop switch and close the aperture. Then set the VTR function lever to STOP.
- (2) Rewind the tape by setting the function lever to REW. Move it to STOP and then to PLAY. When the viewfinder becomes bright, press the camera's start/stop switch, and the playback pictures will be seen in the viewfinder.

NOTE: When checking the playback pictures, use the camera legs as shown to make the viewfinder more easily visible.



To temporarily stop recording

You can stop recording temporarily by pressing the start/stop switch. To restart recording, press the switch again. If the pause is to last for more than 1 minute or so, the battery will be discharged and the tape may be damaged. If you want to stop recording for more than 1 minute, operate the VTR to STOP position.

Sound recording and playback

- The built-in microphone functions as uni-directional when pulled out and as omni-directional when pushed in.
Do not turn the microphone when pulling or pushing.

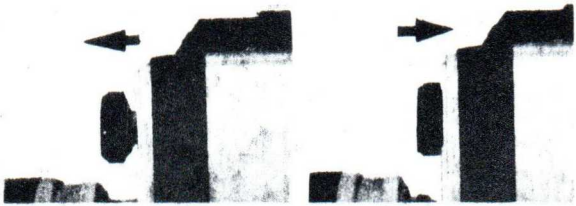

- To monitor the sound during recording or playback, connect an earphone to the VTR "EAR" jack.

NOTES: • Use the wind screen when recording outdoors.

- When an external microphone is connected to the VTR "MIC" jack, the built-in microphone is automatically disconnected.
- When the built-in microphone is switched to uni-directional, the sound from the scene in front of the camera is effectively picked up, but the sensitivity to low frequency sounds decreases.
- When used as the uni-directional microphone, it records the start/stop switching noise at a lower level. Less switching noise occurs when the start/stop switch on the front of the camera is used, instead of the trigger switch on the handgrip.

2. Playback with a TV receiver

Install an RF Converter KR-250E for PV-4800E, KR-251E or KVR-2 for PV-4500 into the RF compartment of VTR and connect the VTR RF OUT jack to the antenna terminal of the TV receiver. Set the TV channel to the channel of the converter used.

You can monitor the picture and sound while recording with the camera.

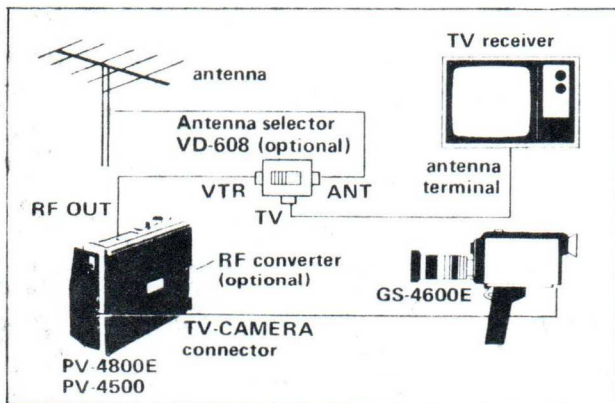

NOTE: When you only monitor the recorded tape on the TV receiver, you do not need to connect the camera to the VTR. Just set the TV-CAMERA switch to TV, and playback monitoring is possible using the VTR function lever.

3. Connection of the GS-4600E to other equipment

Tripod mounting

- Remove the handgrip and fit the tripod in place.
Use the start/stop switch on the front panel.

Video cassette recorder

- When the output of the GS-4600E is connected to the Colour Camera Adapter GA-20E, the video and audio signals are transmitted to the CR-6000E, or other video equipment.

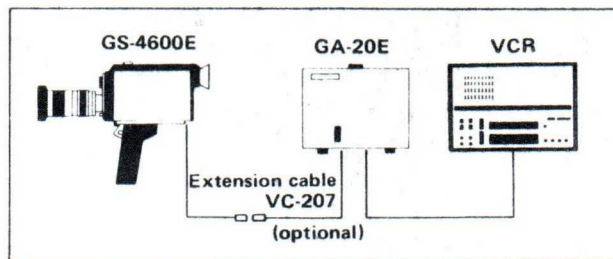

- If the RF Converter is installed in the GA-20E and the GA-20E RF OUT jack is connected to the TV antenna terminal, the picture and sound can be monitored by setting the TV channel to that of the RF converter.





NOTES: • See the GA-20E Instruction Book.

- If you use an extension cable longer than the VC-207 cable, the DC voltage will drop and the picture quality will deteriorate.

ADVANCED TECHNIQUES FOR BETTER RECORDING

1. How to obtain correct exposure

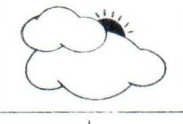
- This camera is provided with an automatic light-level control circuit (ALC) to ensure the recording level is optimum at all times. However, in some cases, the use of the aperture ring to control exposure more accurately will help you obtain better results.
- The following are reference F-stop numbers at which the aperture ring is to be set in different situations.

	Indoors, dark morning/evening . . . f/1.8-4
	Rainy day, bright morning/evening . . f/4-5.6
	In shadows, cloudy day f/5.6-8
	Fine day outdoors f/8-16

NOTE: Make it a rule to close the aperture (set the aperture ring to "C" = closed) and fit the lens cap when you are not using the camera. Otherwise, the vidicon tube will be damaged.

2. Zooming and focusing

- The 6:1 zoom lens provides excellent zoom effects from wide-angle to telephoto as shown in these photographs.
- If you zoom too fast, you will not obtain stable and pleasant pictures. When focusing, set the zoom ring to maximum telephoto; once focused the correct focus will always be maintained throughout the entire zoom range.

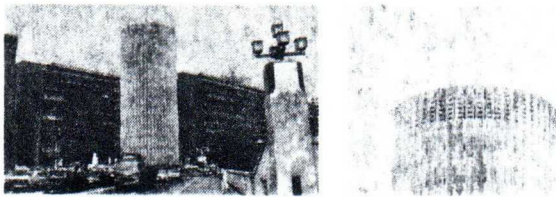

3. Sound recording

- In outdoor recording, background noise will also be recorded. If the background noise is too loud, use an external microphone and place it as close to the sound source as possible. (When the external microphone is connected, the built-in microphone is disconnected.)

4. Front lighting and backlighting

- Shoot with the sun behind you whenever possible. Avoid shooting against the sun unless you want to have special effects, because high contrast will cause unusual pictures.

5. Indoor shooting

- With this camera shooting is possible even in a room with low lighting of less than 100 lux. However, to get good results, an average of 500 lux is needed. In low light conditions, the image lag, that is, trailing ghost image when camera or subject is moved, will increase.

- NOTES:
- It is convenient to mount a movie light on the camera accessory shoe.
 - To further enhance the picture quality, you should increase the number of light sources to reduce the shadowy parts of the subject and illuminate the background of the subject.

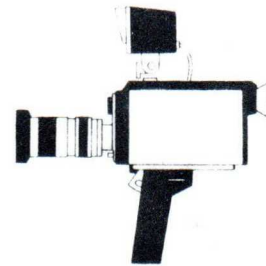

- Avoid directly touching the movie light with your hand because it gets very hot.
- Do not expose the camera lens directly to the movie light.
- Keep the power cord of the movie light as far as possible away from the camera, otherwise the pictures may be distorted.

DISASSEMBLY

1. Covers removal

- (1) Remove the handgrip (1) from the camera. Next remove the eight screws (2) and (3) which are located on the top and bottom of the camera. The side covers (4) and (5) and the top panel (6) may now be pulled off.

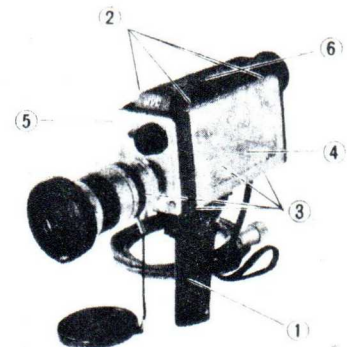

2. Location of principal parts

Side 1 of the chassis

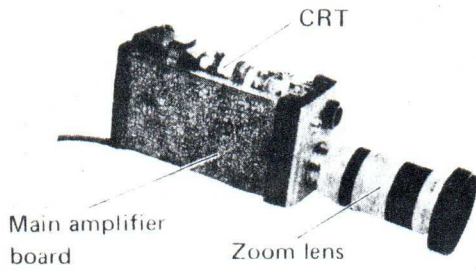

Side 2 of the chassis

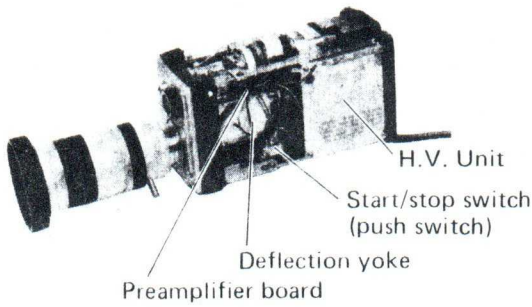

3. How to remove the main amplifier board

- (1) Remove four screws ① and ②, and pull out the rear panel ⑤ toward the rear.
- (2) Remove four screws ③ and ④, and pull out the front panel ⑥ slightly forward.
- (3) Remove the board by gently pulling it forward.

NOTE: Be careful that the wiring harness does not be disconnected.

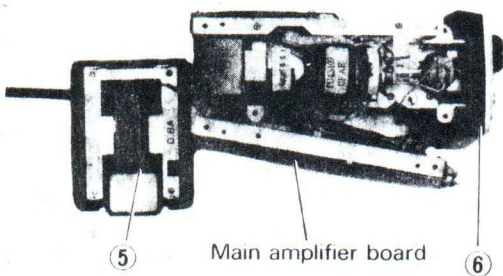
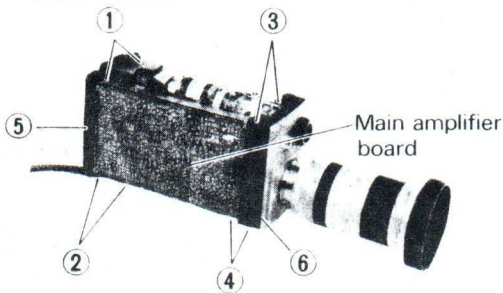

4. Replacement and adjustment of vidicon tube

If the vidicon tube beam weakens, or if it is scratched or has a burned out screen or suffers some other damage, replace the vidicon tube following the procedure given below.

- (1) Removal procedure for the vidicon tube
 - 1) Remove the side and top covers according to "Covers Removal".
 - 2) Take out the rear cover ③ toward the rear according to "How to remove the main amplifier board".
 - 3) Remove the zoom lens from the camera.
 - 4) Remove four screws ① and then take the H.V. unit board ② from the chassis.
 - 5) Carefully remove the vidicon socket.
 - 6) Loosen the vidicon fixing screw ④ and remove the vidicon tube forward.

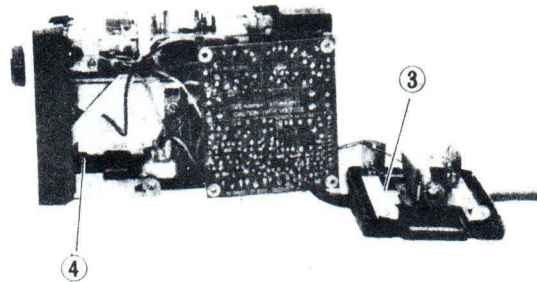
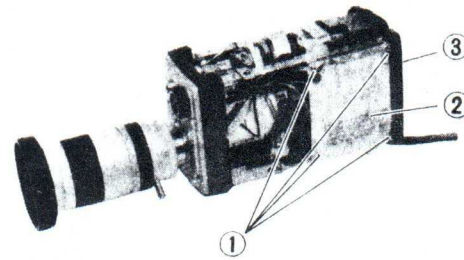

- (2) Mounting procedure for the vidicon tube

NOTE: After mounting, the vidicon surface and lens should be cleaned with a soft lint-free cloth.

- 1) Install it fully in position.

NOTE: Install the vidicon tube so that its non-connection pin comes to the right side when viewed from the front.
- 2) Tighten the vidicon fixing screw moderately firmly.

NOTE: Do not tighten the screw excessively. Otherwise the vidicon tube will be broken.
- 3) Connect the vidicon tube to its socket.
- 4) Install the H.V. unit, rear cover and zoom lens.

(3) Flange-back (back focus) adjustment

NOTE: Check if the vidicon tube is inserted in back of the deflecting coil.

- 1) Loosen four screws ① which mounted on the chassis.
- 2) Set the aperture to F1.8.
- 3) Set the focus ring to INFINITY and select an objective as far away as practical. (50 meters or more)
- 4) Zoom to full close up.
- 5) Move the deflecting coil back and forth until the best focus is obtained.
- 6) Zoom to long and move the deflecting coil to see if focus can be improved.
- 7) Repeat until no further improvement is possible.
- 8) Select an objective about 1.2 meters from the camera.
- 9) Zoom to close up and rotate the focus ring until the best focus is obtained.
- 10) Zoom to long and rotate the focus ring.
- 11) If focus can be improved, repeat steps 3) through 10) until no further improvement is possible.
- 12) Tighten four screws ①.

NOTE: Check the electric focus is obtained before flange back adjustment.

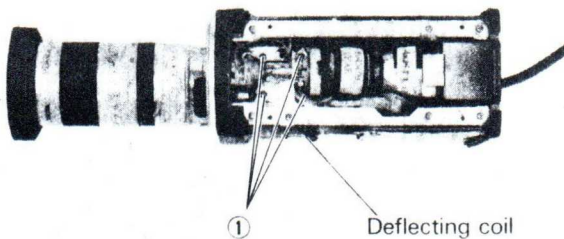

OVERALL ALIGNMENT PROCEDURE

The equipment was completely checked and adjusted before shipping from the factory. Before starting repairs in any way, localize the trouble using appropriate instruments. Then do repairs, replacement or adjustment as necessary.

1. Equipment required

- Oscilloscope
- Monochrome monitor
- Camera adaptor: GA-20E
- Light box with resolution pattern: $6,000 \pm 20$ lux

2. Preliminary setup

The camera must be placed on a stable mount and leveled, front to back and side to side. The test pattern or lightbox must be mounted so that the center of each card is in direct line with the lens and surface of the card is perpendicular to the camera line of sight. The pattern should be approximately 1.2m from the front of the camera.

Connect the camera to GA-20E and feed the video out from the GA-20E to the monochrome monitor.

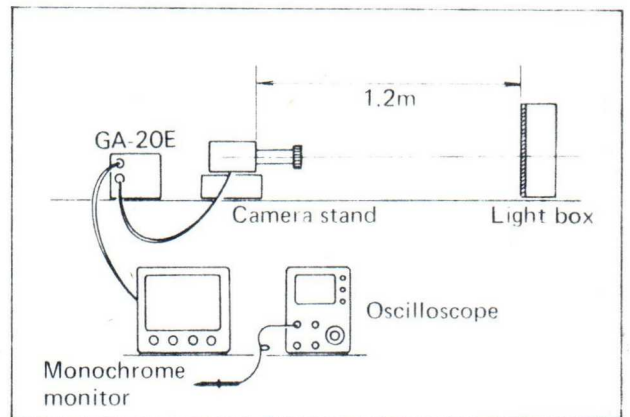

3. Oscillator frequency adjustment

NOTE: Close the aperture on the lens.

(1) Vertical frequency adjustment

Cutting VD (Vertical Drive) pulse coming from the GA-20E, adjust the period of vertical oscillator frequency to about 22.2ms at IC2-⑥ with R46 (V. Freq.).

NOTE: This adjustment is not necessary if picture on the monitor does not vibrate vertically after turning on the power. Make sure of the condition by repeatedly turning on and off the power a few times.

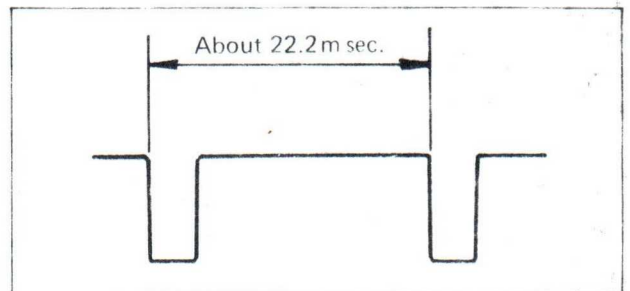

(2) Horizontal frequency adjustment

Using a dual-beam oscilloscope, observing the waveform at P2-⑤ (video output) in ch-1 and that of P2-① (HD input) in ch-2.

Adjust R56 (H. Freq.) so that the leading edge of HD comes in line with the front porch of H. blanking of video output signal.

NOTE: This adjustment is also not necessary if picture on the monitor does not drift or collapse after turning on the power.

Make sure of the condition by repeatedly turning on and off the power a few times.

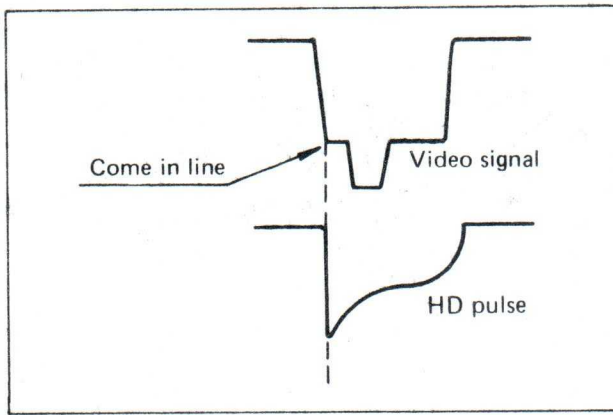

4. Adjustment of the battery alarm circuit

NOTE: Close the aperture on the lens.

Reducing the DC voltage of the GA-20E to 10.6V, adjust R122 (Alarm) so that the LED in the CRT case flickers.

NOTE: Avoid this adjustment except in the case of trouble.

5. Scanning adjustment

(1) Preliminary adjustment of the vidicon alignment
Set the aperture ring to F8.

Using the test pattern (resolution pattern) as an object, and zoom the camera lens until the test pattern is "Just Scanning" on the monitor.

Turn the two alignment magnet rings so that the picture of the test pattern focused uniformly on the whole screen of the monitor.

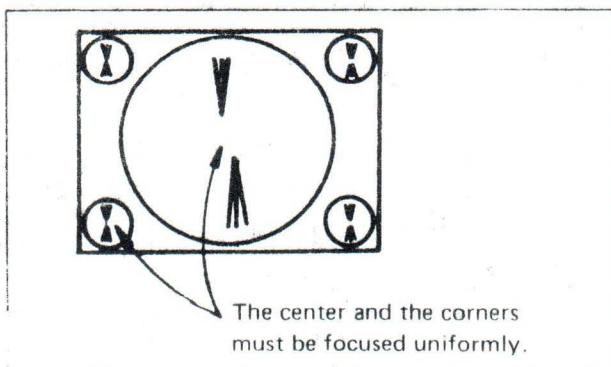

(2) Adjustment of scanning size and the centering

Set the aperture ring to F8.

Adjust R69 (H. size) and R95 (V. height) so that the vidicon surface appears as a circle on the monitor. Then adjust R105 (V. center) so that the circle comes to the center of the monitor.

NOTE: If the circle deviates excessively from the center of the monitor, repeat (1) "Preliminary adjustment of the vidicon alignment".

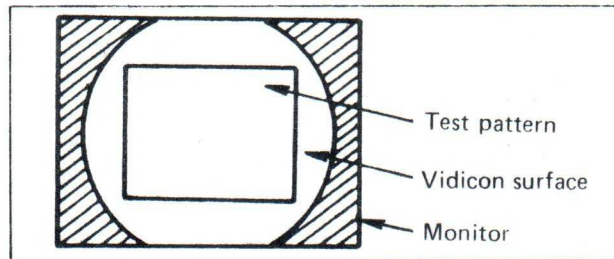

Zoom the camera lens until the resolution pattern as large as possible so that the pattern is not distorted. Keeping the camera and lens in this condition, adjust R69 (H. size) and R95 (V. Height) again for a correct aspect ratio. i.e.: The wedges at top and bottom of the test pattern, also the wedges on the sides of the test pattern reach the vertical and horizontal raster limits.

NOTE: Bad example of the adjustment are shown in the below Fig.

- a) Over scanning (Pincushion distortion)
In this case, linearity and shading deteriorate.
- b) Under scanning
In this case, the vidicon face is not used most effectively. The resolution and signal to noise ratio fall short.

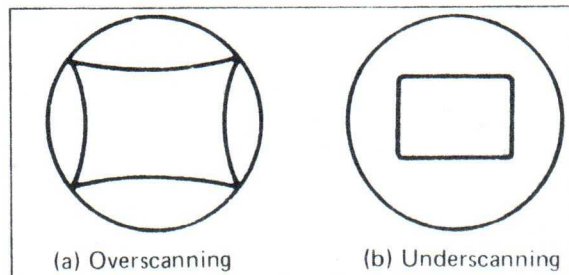

(3) Fine adjustment of the vidicon alignment

Set the aperture ring to F8.

Using the resolution pattern as an object, and zoom the camera lens until the pattern is "Just Scanning" on the monitor.

Turn the two alignment magnet rings so that the picture of the test pattern focused uniformly on the screen of the monitor. Adjust R13 (Focus) at this time so that the resolution becomes optimum.

NOTE: Fix the alignment rings with adhesive when this adjustment has finished.

REPACKING

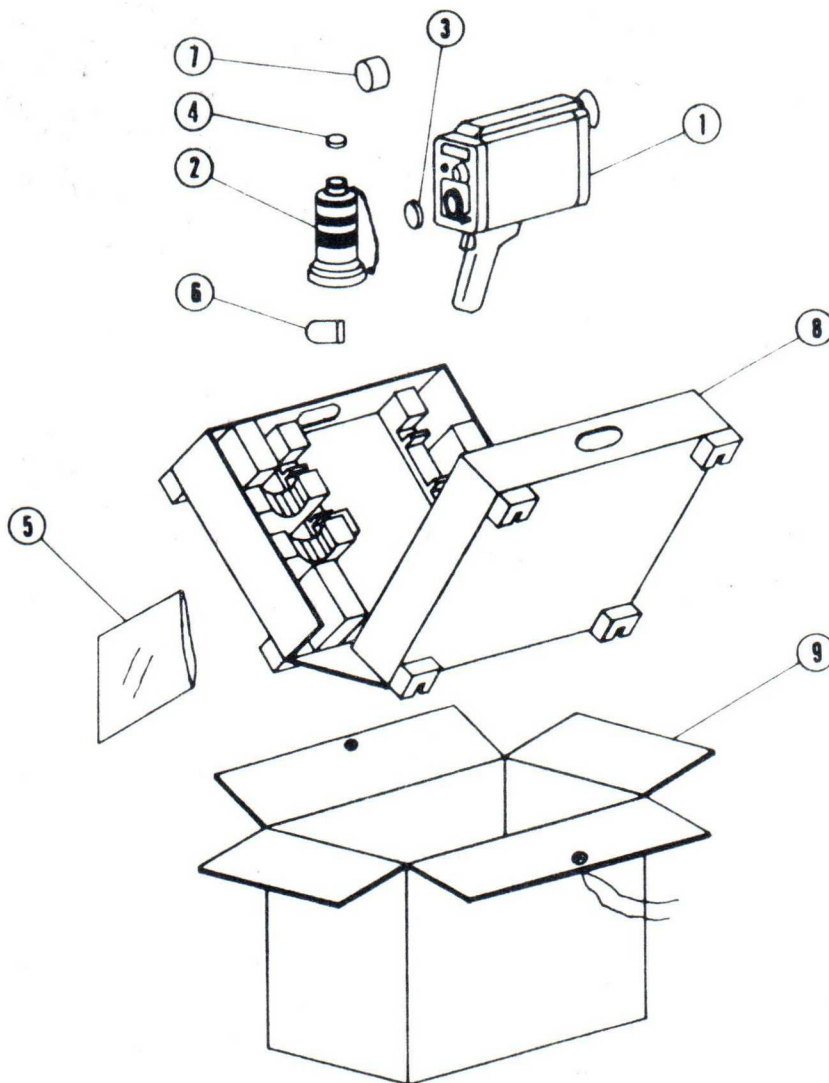

1. Remove the zoom lens ② from the camera ①, and attach the vidicon cap ③ to the lens mount of camera.
2. Attach the mic. cover ⑦ to the mike of camera ①, and then pack the camera into the poly bag.
3. Attach the lens cap ④ to the zoom lens, and pack the lens ② into the poly bag.
4. Put the lens and the camera into the cushion ⑧, and insert it into the case ⑨.

No.	Part No.	Description	No.	Part No.	Description
1		Camera	7	PUP10023-9	Mic. cover
2		Zoom lens	8	PUP10023A	Cushion
3	GA40069	Vidicon cap	9	PUP30194-4	Case
4	PU43431-3	Lens cap		QPGA035-04505	Poly bag
5		Accessories		QPGA020-03005	Poly bag
6		Desiccant			

DIAGRAMS AND CIRCUIT BOARDS

Block Diagram

