

ORTEC

100 MIDLAND ROAD, OAK RIDGE, TENNESSEE, 37830
AREA CODE (615) 483-8451 TWX 810-572-1078

INSTRUCTION

MANUAL

428

DETECTOR

BIAS

SUPPLY

ORTEC[®]

INSTRUCTION MANUAL MODEL 428 DETECTOR BIAS SUPPLY

Serial No. _____

Purchaser _____

Date Issued _____



P.O. BOX C
OAK RIDGE, TENNESSEE 37830
Telephone (615) 483-8451
TWX 810-572-1078

TABLE OF CONTENTS

	Page
WARRANTY	
PHOTOGRAPH	
1. DESCRIPTION	1-1
2. SPECIFICATIONS	2-1
3. INSTALLATIONS	3-1
3.1 General Installation Considerations	3-1
3.2 Connection to Power — Nuclear Standard Bin, ORTEC 401A/402A	3-1
3.3 Connections to the ORTEC 428	3-1
3.4 Linear Output Signal Connections and Terminating Impedance Considerations	3-2
4. OPERATING INSTRUCTIONS	4-1
4.1 Initial Testing	4-1
4.2 Polarity Selection	4-1
4.3 Bias Voltage Indicator Light	4-1
4.4 Bias Voltage Selectors	4-1
4.5 Current Monitor Jacks	4-1
4.6 Undesirable Leakage Currents	4-3
4.7 Determination of Actual Detector Bias	4-4
4.8 Guard-Ring Voltage Supply	4-4
4.9 Detector Considerations at High Bias Voltages	4-4
5. CIRCUIT DESCRIPTION	5-1
6. MAINTENANCE	6-1
6.1 Testing Performance of Bias Supply	6-1
6.2 Adjustments	6-2
6.3 Troubleshooting Suggestions	6-3

STANDARD WARRANTY FOR ORTEC ELECTRONIC INSTRUMENTS

DAMAGE IN TRANSIT

Shipments should be examined immediately upon receipt for evidence of external or concealed damage. The carrier making delivery should be notified immediately of any such damage, since the carrier is normally liable for damage in shipment. Packing materials, waybills, and other such documentation should be preserved in order to establish claims. After such notification to the carrier, notify ORTEC of the circumstances so that we may assist in damage claims and in providing replacement equipment when necessary.

WARRANTY

ORTEC warrants its electronic products to be free from defects in workmanship and materials, other than vacuum tubes and semiconductors, for a period of twelve months from date of shipment, provided that the equipment has been used in a proper manner and not subjected to abuse. Repairs or replacement, at ORTEC option, will be made without charge at the ORTEC factory. Shipping expense will be to the account of the customer except in cases of defects discovered upon initial operation. Warranties of vacuum tubes and semiconductors, as made by their manufacturers, will be extended to our customers only to the extent of the manufacturers' liability to ORTEC. Specially selected vacuum tubes or semiconductors cannot be warranted. ORTEC reserves the right to modify the design of its products without incurring responsibility for modification of previously manufactured units. Since installation conditions are beyond our control, ORTEC does not assume any risks or liabilities associated with the methods of installation, or installation results.

QUALITY CONTROL

Before being approved for shipment, each ORTEC instrument must pass a stringent set of quality control tests designed to expose any flaws in materials or workmanship. Permanent records of these tests are maintained for use in warranty repair and as a source of statistical information for design improvements.

REPAIR SERVICE

ORTEC instruments not in warranty may be returned to the factory for repairs or checkout at modest expense to the customer. Standard procedure requires that returned instruments pass the same quality control tests as those used for new production instruments. Please contact the factory for instructions before shipping equipment.

ORTEC®

MODEL 428

**DETECTOR
BIAS SUPPLY**

A



0-1000V

B



0-1000V

CURRENT
MONITOR

POS OFF NEG



OUTPUT



+12V 0mA
-12V 0mA
+24V 155mA
-24V 155mA

MODEL 428
DETECTOR BIAS SUPPLY

1. DESCRIPTION

The ORTEC 428 Detector Bias Supply provides bias voltage of either polarity for two semiconductor detectors. The voltages are selected independently by 10-turn, direct reading potentiometers. The polarity is controlled by a front panel switch. Jacks are provided on the front panel for external monitoring of the current in each detector. The output of the 428 is short-circuit proof and has an output impedance of approximately 1.3 megohms. The 428 is a double-width module designed to meet the recommended standards outlined in AEC Report TID-20893 (Rev.). It receives necessary operating power from the ORTEC 401A/402A Modular System Bin and Power Supply via the rear module connector.

2. SPECIFICATIONS

Bias Voltage Range: 0-1000 volts

Bias Voltage Outputs: Two each, short-circuit proof

Bias Control: 10-turn, direct readout potentiometers

Bias Polarity: Positive or negative (both outputs same polarity), selectable by front panel switch

Output Impedance: Approximately 1.3 megohms

Current Monitoring Provisions: Front panel jacks accommodate external meter

Noise and Ripple: Less than 0.0002%

Temperature Operating Range: 0 to 50°C

Temperature Stability: 0.02%/°C

Line Stability: Directly proportional to dc power supply stability (less than 0.02% for 105-125V ac when using ORTEC 402A)

Output Connectors: MHV (mates with UG-932/U)

Power Requirements: +24V 165 mA

 -24V 165 mA

Mechanical: Standard double-width module (2.70 x 8.714 inches) per TID-20893

3. INSTALLATION

3.1 General Installation Considerations

The 428, used in conjunction with a 401A/402A Bin and Power Supply, is intended for rack mounting, and therefore it is necessary to ensure that vacuum tube equipment operating in the same rack with the 428 has sufficient cooling air circulating to prevent any localized heating of the all-transistor circuitry used throughout the module. The temperature of equipment mounted in racks can easily exceed the recommended maximum unless precautions are taken. The 428 should not be subjected to temperatures in excess of 120° F (50° C).

3.2 Connection to power — Nuclear Standard Bin, ORTEC 401A/402A

The ORTEC 428 contains no internal power supply, and therefore must obtain power from a Nuclear Standard Bin and Power Supply such as the ORTEC 401A/402A. It is recommended that the bin power supply be turned off when inserting or removing modules. The ORTEC 400 Series is designed so that it is not possible to overload the bin power supply with a full complement of modules in the bin; however, this may not be true when the bin contains modules other than those of ORTEC design, and in such cases, the power supply voltages should be checked after the insertion of modules. The ORTEC 401A/402A has test points on the power supply control panel to monitor the dc voltages.

3.3 Connections to the ORTEC 428

The ORTEC 428 is compatible with all ORTEC amplifiers and preamplifiers which have provisions for an external detector bias voltage. All operating controls and bias voltage output connectors are located on the front panel. The output connectors are the MHV series and mate with type UG-932/U. They are not compatible with ordinary BNC connectors. A perforated shield encloses the unit so that high voltages are not exposed.

WARNING: Do not operate this unit without the protective covers, since lethal voltages are exposed inside the instrument.

Tip jacks are provided for monitoring the current in each detector. The input leads of the ammeter or voltmeter used to monitor the detector current must be capable of floating above chassis and power line ground. The low impedance lead of the meter should be connected to the black tip jack and the high impedance lead to the white tip jack to prevent receiving an erroneous current reading (see Section 4.5). The meter leads should be equipped with tip plugs so that high voltages will not be exposed while monitoring the current.

3.4 Linear Output Signal Connections and Terminating Impedance Considerations

The source impedance of the 0-10 volt standard linear outputs of most 400 Series modules is approximately 1 ohm. Interconnection of linear signals is, thus, non-critical since the input impedance of circuits to be driven is not important in determining the actual signal span, e.g., 0-10 volts, delivered to the following circuit. Paralleling several loads on a single output is therefore permissible while preserving the 0-10 volt signal span. Short lengths of interconnecting coaxial cable (up to approximately 4 feet) need not be terminated. However, if a cable longer than approximately 4 feet is necessary on a linear output, it should be terminated in a resistive load equal to the cable impedance. Since the output impedance is not purely resistive, and is slightly different for each individual module, when a certain given length of coaxial cable is connected and is not terminated in the characteristic impedance of the cable, oscillations will generally be observed. These oscillations can be suppressed for any length of cable by properly terminating the cable either in series at the sending end or in shunt at the receiving end of the line. To properly terminate the cable at the receiving end, it may be necessary to consider the input impedance of the driven circuit, choosing an additional parallel resistor to make the combination produce the desired termination resistance. Series terminating the cable at the sending end may be preferable in some cases where receiving end terminating is not desirable or possible. When series terminating at the sending end, full signal span, i.e., amplitude, is obtained at the receiving end only when it is essentially unloaded or loaded with an impedance many times that of the cable. This may be accomplished by inserting a series resistor equal to the characteristic impedance of the cable internally in the module between the actual amplifier output on the etched board and the output connector. It must be remembered that this impedance is in series with the input impedance of the load being driven, and in the case where the driven load is 900 ohms, a decrease in the signal span of approximately 10% will occur for a 93-ohm transmission line. A more serious loss occurs when the driven load is 93 ohms and the transmission system is 93 ohms. In this case, a 50% loss will occur. BNC connectors with internal terminators are available from a number of connector manufacturers in nominal values of 50, 100, and 1000 ohms. ORTEC stocks in limited quantity both the 50 and 100 ohm BNC terminators. The BNC terminators are quite convenient to use in conjunction with a BNC tee.

4. OPERATING INSTRUCTIONS

4.1 Initial Testing

Refer to Section 6.1 of this manual for information concerning testing performance.

4.2 Polarity Selection

The Polarity Switch is located on the front panel and also serves as an "ON-OFF" switch for power to the 428. When changing the polarity of the output bias voltage, the switch should be stopped in the "OFF" position for a few seconds before switching to the other polarity. This pause in the "OFF" position is necessary to allow the ac starting circuit for the dc to dc converter to recharge.

4.3 Bias Voltage Indicator Light

The Bias Voltage indicator light is a neon light located between the two MHV output connectors. This light indicates the unit is operating properly and bias voltage is available. If the 428 is turned "ON" and the Bias Voltage indicator light does not illuminate, turn the Polarity Selection switch to the "OFF" position for approximately 2 seconds and then return it to the desired polarity. This pause in the "OFF" position is necessary to allow the ac starting circuit for the dc to dc converter to recharge.

4.4 Bias Voltage Selectors

The desired bias voltage for each output is selected by its associated 10-turn potentiometer. The voltage at each output is read directly from its corresponding dial. The 10-turn potentiometers have a linearity of $\pm 0.25\%$. The output impedance is approximately 1.3 megohms which will normally be negligible compared to the detector load resistor in the preamplifier. This resistor typically ranges from 22 to 2000 megohms. The voltage at the output connector of the 428 can be calculated by the formula

$$V_o = V_{\text{dial}} - I_D (1.3 \times 10^6)$$

where V_o = output voltage; V_{dial} = voltage indicated by 10-turn dial; I_D = detector current.

The output impedance of this unit can be decreased by methods given in Section 6.2.2.

4.5 Current Monitor Jacks

Tip jacks are provided on the front panel as a convenience for monitoring the detector current. Typical leakage currents for ordinary room temperature surface barrier detectors range from 0.1 to 1 microamperes. Semiconductor detectors cooled to LN_2 temperature have leakage currents ranging from 0.1 to 10 nanoamperes. This current is measured by connecting a floating ammeter or voltmeter to the Current Monitoring Jacks as shown in Figure 4-1.

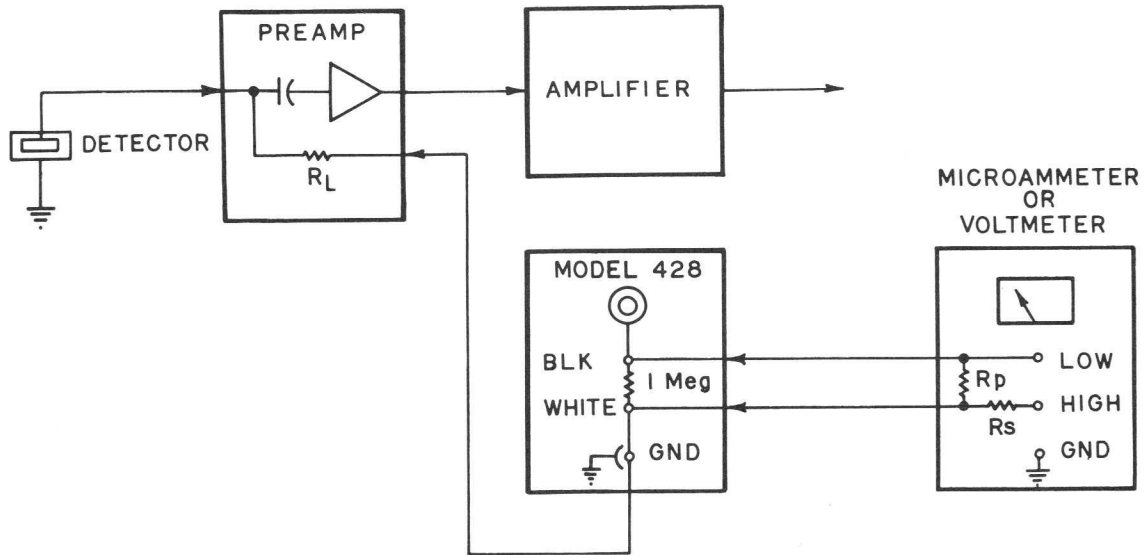

Fig. 4-1 Semiconductor Detector Bias and Current Measuring Circuit using a floating Meter.

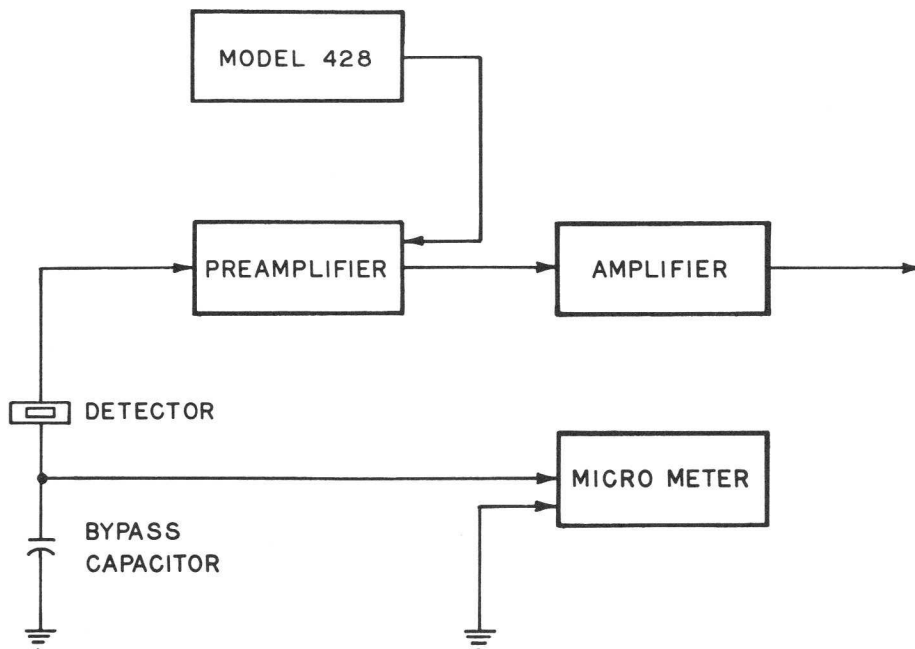

Fig. 4-2 Semiconductor Detector Bias and Current Measuring Circuit using a non-floating meter.

If an electronic type meter operated from the power line is used, the input circuit must be capable of floating above earth and power line ground so that the leakage to ground does not load the bias supply. The low impedance side of the meter must be connected to the black tip jack rather than the white jack; otherwise, the leakage current of the instrument from the low terminal to power line ground will be incorrectly indicated as detector current. If the detector current is measured with an ammeter

$$I_D = \frac{I_M (R_S + 1 \times 10^6)}{1 \times 10^6}$$

where I_D = detector current; I_M = ammeter current; R_S = input resistance of ammeter.

If R_S is very small compared to 1 megohm, then

$$I_D = I_M$$

When a voltmeter is used to measure the detector current

$$I_D = \frac{V_M (R_p + 1 \times 10^6)}{R_p (1 \times 10^6)}$$

where I_D = detector current; V_M = measured voltage; R_p = input resistance of voltmeter.

If R_p is much greater than 1 megohm, then

$$I_D = V_M \times 10^{-6} \text{ amp.}$$

If a microammeter which will not float above powerline and chassis ground is used to measure the detector current, it should be connected as shown in Fig. 4-2.

4.6 Undesirable Leakage Currents

Teflon insulated current monitoring jacks and MHV connectors are used in an effort to reduce leakage currents to a minimum in the 428. Insulation resistance of 1×10^{13} ohms or greater is desirable to measure a detector leakage current of 1 nanoampere at 1000 volts. In order to maintain insulation resistances of this magnitude, the insulators will have to be cleaned frequently. Either freon or methyl alcohol is a good cleaning agent.

It may not be practical to reduce the leakage in external cables and connections to a negligible magnitude. In such cases it may suffice to note the residual leakage current with all wiring in place except the detector itself, and then subtract this residual current from the indicated current to obtain the actual detector current. If the leakage phenomenon is essentially a resistance, then

its value may be computed from Ohm's Law for use in determining the residual current at various voltages, without the necessity of actual measurements.

4.7 Determination of Actual Detector Bias

In addition to its use as an indicator of physical condition of the detector, the detector current serves to allow accurate determination of the actual bias voltage across the detector. This actual voltage differs from that indicated by the bias selector dials by the amount of drop in voltage across the the detector load and filter resistors due to the detector current. Accurate determination of actual detector voltage is important, since it is an important parameter in both the depleted (sensitive) depth of the detector and the collecting field strength.

To obtain the actual detector voltage, one must know the sum of all series resistances in the circuit between voltage source and detector. The resistance of the internal circuit of the 428 may be approximated by 1.3 megohms. Detector load resistors may vary from 10 megohms to 200 megohms in ordinary applications, and may be several thousand megohms in special applications involving cooled detectors. In addition, there is usually a filter resistor of one or more megohms near and in series with the load resistor. The values of these resistors can usually be ascertained from the schematic diagram of the preamplifier used. Once having determined the total series resistance, the loss of bias in that resistance can be calculated by Ohm's law.

4.8 Guard-Ring Voltage Supply

When using detectors that require a separate bias connection to a guard ring, the 428 will prove convenient in that the signal electrode bias can be taken from one bias output and guard-ring potential from the other. In this way the two potentials can be varied independently of each other to determine the optimum biasing condition. The usual optimum is obtained when both are nearly the same, but a small difference is sometimes beneficial. In general, that setting which minimizes the signal electrode current will be near optimum.

4.9 Detector Considerations at High Bias Voltages

Semiconductor radiation detectors that utilize more than a few hundred volts bias generally require some care in the application of that bias to reduce the risk of damaging the detector. It is helpful to observe the noise output of the main amplifier with an oscilloscope while the bias voltage is advanced. Small breakdown phenomena which die out in less than a minute can be observed after a bias increase. For greatest safety, it is advisable to approach the final operating bias in small increments, with brief aging periods between increments.

5. CIRCUIT DESCRIPTION

The 428 is a dc to dc converter which converts 48 volts to 1000 volts. The circuitry associated with the primary of the transformer composes a square wave oscillator powered by highly regulated plus and minus 24 volts. Transistors Q1 and Q2 operate alternately in the saturated and off mode; therefore, a negligible amount of power is dissipated in them. When the power switch is turned on, the current which charges capacitor C4 flows in the base circuits of Q1 and Q2. The transistor with the highest gain (for this discussion we will arbitrarily choose Q1) will saturate first. Once the turn-on cycle has started, positive feedback is maintained through the feedback winding N_F , until the transformer core saturates. At this time the loop gain becomes less than unity and Q1 is turned off. When Q1 starts to turn off, the flux in the transformer core produces a positive signal at the base of Q2, causing it to turn on and saturate. The above cycle is again followed causing an oscillation at approximately 10 kc. This oscillation is started by the current which charges capacitor C4 when the power switch is turned on. If this capacitor is not fully discharged when the power switch is turned on, the oscillations will not start and voltage will not be available at the output connectors. If this happens, turn the Polarity Selection switch to the "OFF" position for about 2 seconds, and then return it to the desired polarity. This will permit C4 to fully discharge.

The circuitry in the transformer secondary consists of a full wave diode bridge, an RC filter network, a neon voltage indicator light, and two 10-turn potentiometers for the selection of the output voltages. Diodes D1-D4 constitute a full wave rectifier bridge. The switch immediately after the bridge permits selection of the output voltage polarity.

The voltage across the 10-turn potentiometers can be adjusted to 1000 volts by trimpot R12. This adjustment should be made with an insulated screwdriver through one of the holes in the top cover. The 110K resistors (R18 and R19) in series with the output limit the current and prevent the occurrence of lethal voltages at TP1 and TP3. The detector current may be monitored by connecting either an ammeter or voltmeter across resistors R15 or R17.

6. MAINTENANCE

6.1 Testing Performance of Bias Supply

6.1.1 Introduction

The following paragraphs are intended as aids in the installation and checkout of the 428. These instructions present information on the front panel controls, output voltages and internal adjustments.

6.1.2 Test Equipment

The following or equivalent test equipment is needed:

- (1) Nuclear Standard Bin, ORTEC 401A/402A
- (2) Oscilloscope with an input coupling capacitor rated at more than 500 volts
- (3) Voltmeter with input impedance of 100 megohms or greater on the 1000V scale
- (4) Schematic of 428

6.1.3 Preliminary Procedures

- (1) Visually check the module for possible damage due to shipment.
- (2) Connect ac power to Nuclear Standard Bin, ORTEC 401A/402A
- (3) Plug module into Bin and check for proper mechanical alignment.
- (4) Ensure that the Polarity Selection switch on the ORTEC 428 is in the "OFF" position.
- (5) Switch on the ac power and check the dc power supply voltages at the test points on the 401A Power Supply control panel.

6.1.4 Performance Tests

- (1) Set the bias selector potentiometers to zero.
- (2) Set the voltmeter to the 1000 volt scale and connect it to output A.
- (3) Rotate the Polarity Selection switch to "POS".
- (4) Increase the potentiometer associated with output A to 1000 and check the output voltage for approximately 1000 volts. The loading effect of the voltmeter on the circuit should be considered. For example, a voltmeter with an input impedance of 100 megohms will produce a 10-microamp current drain on the output. This output current will produce an 11-volt drop across the series 1.1 megohm output resistance (R15 and R18); therefore, the voltmeter should read 989 volts. If the output voltage is not in agreement with the dial reading, see Section 6.2.1 for calibration procedure.

- (5) Reduce the potentiometer back to zero and check the potentiometer linearity by comparing the output voltage versus the potentiometer dial reading.
- (6) Connect the voltmeter to output B and repeat steps 4 and 5.
- (7) Turn the Polarity Selection switch to "OFF" for about 2 seconds and then to "NEG" and repeat steps 4, 5, and 6.
- (8) Set the output voltage to zero and connect output A to the ac-coupled input of an oscilloscope with a coaxial cable. Increase the output voltage to 500 volts and check the ripple. It should be less than 1 millivolt peak to peak.

6.2 Adjustments

6.2.1 Calibration Adjustments

- (1) If the output voltage does not agree with the dial reading it should be recalibrated using the following procedure:
 - (a) Ensure that the 428 Polarity Selection switch is in the "OFF" position.
 - (b) Apply power to the 428 through a 401A C-1 or equivalent cable. (The module must be out of the Bin when this adjustment is made).
 - (c) Switch on the ac power and check the dc power supply voltages at the test points on the 402A Power Supply control panel.
 - (d) Select the 1000 volt scale on a voltmeter and connect it to output A. The input impedance of the voltmeter should be 100 megohms or greater on this scale.
 - (e) Rotate the Polarity Selection switch to "POS".
 - (f) Increase the potentiometer associated with output A to 1000 and check the output voltage for approximately 1000 volts. The loading effect of the voltmeter on the circuit should be considered before the voltage is adjusted. For example, a voltmeter with an input impedance of 100 megohms will produce a 10-microamp current drain on the output. This output current will produce an 11-volt drop across the series 1.1 megohm output resistance (R15 and R18); therefore, the voltmeter should read 989 volts.
 - (g) The output voltage may be calibrated by adjusting resistor R12. Access to R12 is available through a hole in the top cover of the module. **CAUTION:** Only an insulated screwdriver should be used to make this adjustment as lethal voltages exist inside. This adjustment will calibrate the unit for both positive and negative polarity.

- (h) Reduce the potentiometer to zero and check the output voltage versus the potentiometer dial reading at several points.

6.2.2 Reduction of the Output Impedance

- (1) Resistors R15 and R17 provide a method of measuring the detector current with a voltmeter. (See Section 4.5 for details). If these resistors are shorted the output impedance will be reduced by 1 megohm.
- (2) Resistors R18 and R19 limit the current at the current monitoring jacks and prevent these voltages from being lethal. If these resistors are removed, the output impedance will be reduced by 110K, but the voltages at the current monitoring jacks will be lethal.

6.3 Troubleshooting Suggestions

- (1) Ensure that the proper dc voltage is supplied to the module.
- (2) Turn the Polarity Selection switch to the "OFF" position for approximately 2 seconds and ensure that the output is not shorted.
- (3) Return the Polarity Selection switch to the desired polarity.
- (4) Transistors Q1 and Q2 have been selected for a V_{ce0} greater than 140 volts. Replacement transistors should be selected for the same high V_{ce0} .
- (5) The 428 may be returned to ORTEC for repair service at nominal cost. The standardized procedure requires that each repaired instrument receive the same extensive quality control tests that a new instrument receives.

**BIN/MODULE CONNECTOR PIN ASSIGNMENTS
FOR AEC STANDARD NUCLEAR INSTRUMENT MODULES
PER TID-20893**

Pin	Function	Pin	Function
1	+3 volts	23	Reserved
2	-3 volts	24	Reserved
3	Spare Bus	25	Reserved
4	Reserved Bus	26	Spare
5	Coaxial	27	Spare
6	Coaxial	*28	+24 volts
7	Coaxial	*29	-24 volts
8	200 volts dc	30	Spare Bus
9	Spare	31	Carry No. 2
*10	+6 volts	32	Spare
*11	-6 volts	*33	115 volts ac (Hot)
12	Reserved Bus	*34	Power Return Ground,
13	Carry No. 1	35	Reset
14	Spare	36	Gate
15	Reserved	37	Spare
*16	+12 volts	38	Coaxial
*17	-12 volts	39	Coaxial
18	Spare Bus	40	Coaxial
19	Reserved Bus	*41	115 volts ac (Neut.)
20	Spare	*42	High Quality Ground
21	Spare	G	Ground Guide Pin
22	Reserved		

**These pins are installed and wired in parallel in the ORTEC 401A Modular System Bin.*

The transistor types installed in your instrument may differ from those shown in the schematic diagram. In such cases, necessary replacements can be made with either the type shown in the diagram or the type actually used in the instrument.