

RCA PICTURE TUBE GUIDE

Black-and-White Picture Tubes

Greatest Deflection Angle (Approx.) Degrees	Heater Volts/mA	Focusing Method §	Design-Maximum Anode Volts	RCA Type
ELECTROSTATIC DEFLECTION TYPE				
Round Glass Envelope				
	6.3/600	E	6500	7JP4
MAGNETIC DEFLECTION TYPES				
Round Glass Envelope				
50	6.3/600	E	29,500	5TP4
52	6.3/600	M	15,500	16LP4A
55	6.3/600	M	13,000	10BP4A
55	6.3/600	M	13,000	10FP4A
55	6.3/600	M	13,000	12KP4A
60	6.3/600	M	16,500	16DP4A
70	6.3/600	M	17,500	16WP4A
Rectangular Metal Envelope				
70	6.3/600	M	17,500	17CP4 ^d
70	6.3/600	E	17,500	17TP4 ^d
Rectangular Glass Envelope				
Conventional Rectangular Glass Types				
70	6.3/600	M	17,500	16RP4B
70	6.3/600	M	15,500	16TP4
70	6.3/600	M	17,500	17BP4D
70	6.3/600	E	17,500	17HP4C
70	6.3/600	E	17,500	17LP4B ^a
70	6.3/600	M	20,000	17QP4B
70	6.3/600	M	20,000	20DP4D
70	6.3/600	E	17,500	20HP4E
70	6.3/600	M	20,000	21EP4C ^a
70	6.3/600	E	20,000	21FP4D ^a
70	6.3/600	M	20,000	21WP4B

RCA PICTURE TUBE GUIDE

Black-and-White Picture Tubes

Greatest Deflection Angle (Approx.) Degrees	Heater Volts/mA	Focusing Method §	Design-Maximum Anode Volts	RCA Type
Rectangular Glass Envelope Cont'd				
Conventional Rectangular Glass Types				
70	6.3/600	E	20,000	21XP4B
70	6.3/600	E	20,000	21YP4B
70	6.3/600	M	20,000	21ZP4C
72	6.3/600	E	22,000	21AVP4C
72	6.3/600	M	20,000	21AWP4A
90	6.3/600	E	9000	8DP4
90	8.4/450	E	15,500	14ATP4
90	6.3/600	E	15,500	14WP4
90	6.3/600	E	17,500	17BJP4
90	6.3/600	E	17,500	17CFP4
90	6.3/600	E	17,500	17CYP4
90	6.3/600	M	20,000	21AMP4B
90	6.3/600	E	22,000	21CBP4A
90	6.3/600	E	22,000	21DLP4
90	6.3/600	E	22,000	21DSP4 ^b
90	6.3/600	E	22,000	24AEP4
90	6.3/600	E	22,000	24ATP4 ^b
90	6.3/600	E	22,000	24AUP4
90	6.3/600	M	22,000	24CP4B
90	6.3/600	M	22,000	27RP4A
92	6.3/600	E	20,000	19BDP4 ^b
92	6.3/600	E	22,000	23AHP4
92	6.3/600	E	22,000	23ASP4
92	6.3/600	E	25,000	23BJP4 ^b
92	6.3/450	E	22,000	23CGP4
94	6.3/600	E	23,000	23DAP4 ^b
110	6.3/450	E	15,000	11CP4

Black-and-White Picture Tubes

Greatest Deflection Angle (Approx.) Degrees	Heater Volts/mA	Focusing Method §	Design-Maximum Anode Volts	RCA Type
Rectangular Glass Envelope Cont'd				
Conventional Rectangular Glass Types				
110	8.4/450	E	17,500	17CDP4
110	6.3/600	E	17,500	17CSP4
110	2.68/450	E	17,500	17DAP4
110	6.3/600	E	23,000	17DKP4
110	6.3/450	E	17,500	17DQP4 ^b
110	2.68/450	E	17,500	17DRP4 ^c
110	6.3/600	E	20,000	17DSP4
110	6.3/450	E	17,500	17DXP4
110	6.3/450	E	20,000	17EFP4
110	6.3/600	E	20,000	21CQP4
110	6.3/600	E	22,000	21DEP4A
110	6.3/600	E	20,000	21DFP4
110	6.3/450	E	20,000	21DHP4
110	6.3/600	E	20,000	21EQP4
110	6.3/600	E	22,000	21FAP4
110	6.3/600	E	20,000	21FDP4
110	6.3/600	E	22,000	23ARP4
110	6.3/600	E	22,000	23DBP4 ^b
110	6.3/600	E	22,000	24AHP4
110	6.3/600	E	22,000	24BAP4 ^b
110	6.3/600	E	20,000	24BEP4
114	6.3/450	E	20,000	16AYP4
114	2.68/450	E	20,000	19ABP4
114	6.3/450	E	17,500	19AHP4
114	6.3/450	E	20,000	19AJP4 ^b
114	6.3/600	E	23,000	19AVP4
114	6.3/450	E	23,000	19AYP4

Black-and-White Picture Tubes

Greatest Deflection Angle (Approx.) Degrees	Heater Volts/mA	Focusing Method §	Design-Maximum Anode Volts	RCA Type
Rectangular Glass Envelope Cont'd				
Conventional Rectangular Glass Types				
114	6.3/600	E	23,000	19BTP4
114	6.3/600	E	20,000	19CHP4 ^b
114	6.3/450	E	20,000	19CMP4 ^b
114	6.3/600	E	20,000	19CXP4 ^b
114	6.3/600	E	20,000	19XP4
114	6.3/600	E	20,000	19YP4
114	6.3/450	E	22,000	20RP4
114	6.3/450	E	23,500	23CQP4
114	6.3/600	E	23,500	23FP4A
114	6.3/600	E	22,000	23MP4
114	6.3/600	E	22,000	23NP4 ^b
Bi-Panel Rectangular Glass Types				
92	6.3/600	E	22,000	23BDP4 ^d
92	6.3/600	E	25,000	23BKP4
92	6.3/600	E	25,000	23BLP4 ^e
92	6.3/600	E	25,000	23BTP4
92	6.3/600	E	22,000	23YP4
110	6.3/600	E	22,000	23BGP4 ^b
110	6.3/450	E	23,000	23BQP4
110	6.3/450	E	23,000	23CBP4 ^d
110	6.3/600	E	22,000	23CP4
110	6.3/600	E	23,500	23CP4A
110	6.3/600	E	22,000	23EP4 ^b
110	6.3/600	E	22,000	23GP4
110	6.3/450	E	22,000	23JP4 ^b
114	6.3/600	E	20,000	19AFP4
114	6.3/600	E	20,000	19AUP4 ^d

Black-and-White Picture Tubes

Greatest Deflection Angle (Approx.) Degrees	Heater Volts/mA	Focusing Method §	Design-Maximum Anode Volts	RCA Type
Rectangular Glass Envelope Cont'd				
Filled Rim Rectangular Glass Types				
92	6.3/600	E	25,000	23EYP4 ^b
110	6.3/450	E	15,000	11GP4
110	6.3/450	E	23,000	23FRP4 ^b
110	6.3/600	E	23,000	23FSP4
114	6.3/600	E	23,000	19EBP4
114	6.3/450	E	21,000	19EGP4 ^b
Banded Rectangular Glass Types				
90	12.0/75	E	12,000	9WP4
92	6.3/450	E	25,000	23EKP4
92	6.3/600	E	25,000	23ENP4
92	6.3/600	E	25,000	23FBP4 ^e
94	6.3/450	E	23,500	23EZP4 ^{b,g}
110	6.3/450	E	15,000	11HP4A
110	6.3/450	E	16,000	12BNP4A
110	4.2/450	E	14,000	12CNP4
110	6.3/600	E	23,000	23ETP4
110	6.3/450	E	23,000	23FDP4 ^b
110	6.3/450	E	23,000	23FMP4 ^b
110	6.3/450	E	23,000	23GJP4A ^b
110	6.3/600	E	23,000	23GSP4 ^g
110	6.3/450	E	22,000	23GWP4 ^b
110	6.3/450	E	23,000	23HFP4A
110	6.3/450	E	23,000	23HGP4 ^g
110	6.3/450	E	23,500	23HUP4A ^b
110	6.3/450	E	22,000	23HWP4A ^{b,g}
110	6.3/450	E	23,000	23HXP4
110	6.3/450	E	23,000	23JEP4
110	6.3/450	E	23,500	23JGP4 ^b
114	6.3/450	E	20,000	16BGP4
114	6.3/450	E	20,000	16CHP4A ^b
114	6.3/450	E	18,000	16CMP4A
114	6.3/450	E	22,000	17EMP4 ^b

RCA PICTURE TUBE GUIDE

Black-and-White Picture Tubes

Greatest Deflection Angle (Approx.) Degrees	Heater Volts/mA	Focus- ing Method §	Design- Maximum Anode Volts	RCA Type
Rectangular Glass Envelope Cont'd				
Banded Rectangular Glass Tubes				
114	6.3/450	E	23,000	19DQP4
114	6.3/600	E	23,000	19DRP4
114	6.3/600	E	20,000	19DSP4 ^b
114	6.3/450	E	20,000	19EAP4 ^b
114	6.3/450	E	22,000	19DUP4 ^b
114	6.3/600	E	18,000	19EHP4A
114	6.3/450	E	21,000	19ENP4A ^b
114	6.3/450	E	23,500	19FEP4B ^b
114	6.3/450	E	18,000	19FJP4A
114	6.3/450	E	23,000	19FLP4
114	6.3/600	E	23,000	19FNP4 ^g
114	6.3/450	E	20,000	19FQP4 ^{b, g}
114	6.3/450	E	23,000	19GEP4A ^g
114	6.3/450	E	23,000	19GJP4A
114	6.3/450	E	23,000	20SP4 ^b
114	6.3/450	E	23,000	20TP4
114	6.3/450	E	23,000	21FVP4
114	6.3/450	E	22,000	21FYP4 ^{b, g}
114	6.3/450	E	23,500	21GAP4A ^b
114	6.3/450	E	23,000	23EQP4
114	6.3/600	E	23,000	23ERP4

Color Picture Tubes

Greatest Deflection Angle (Approx.) Degrees	Heater Volts/mA	Focusing Method §	Design-Maximum Anode Volts	RCA Type
ROUND GLASS ENVELOPE				
Conventional Types				
45	6.3/1800	E	22,000	15GP22
70	6.3/1600	E	27,500	21CYP22A
70	6.3/1800	E	27,500	21FBP22
70	6.3/1800	E	27,500	21FBP22A ^f
70	6.3/1800	E	27,500	21GUP22 ^f
Integral Protective Window Types				
70	6.3/1800	E	27,500	21FJP22 ^d
70	6.3/1800	E	27,500	21FJP22A ^{d, f}
70	6.3/1800	E	27,500	21GVP22 ^{d, f}
ROUND METAL ENVELOPE				
70	6.3/1800	E	27,500	21AXP22A
RECTANGULAR GLASS ENVELOPE				
Conventional Types				
90	6.3/900	E	22,500	15KP22 ^f
90	6.3/900	E	27,500	19EXP22 ^f
90	6.3/900	E	27,500	19GVP22 ^f
90	6.3/900	E	27,500	22KP22 ^f
90	6.3/900	E	27,500	25BP22A ^f
90	6.3/900	E	27,500	25YP22 ^f
Integral Protective Window Types				
90	6.3/900	E	22,500	15LP22 ^{d, f}
90	6.3/900	E	27,500	19EYP22 ^{d, f}
90	6.3/900	E	27,500	19GWP22 ^{d, f}
90	6.3/900	E	27,500	22JP22 ^{d, f}
90	6.3/900	E	27,500	25AP22A ^{d, f}
90	6.3/900	E	27,500	25XP22 ^{d, f}
92	6.3/1350	E	27,500	23EGP22A ^d

Color Picture Tubes

Greatest Deflection Angle (Approx.) Degrees	Heater Volts/mA	Focusing Method §	Design-Maximum Anode Volts	RCA Type
Banded Types				
90	6.3/900	E	22,500	15NP22 ^f
90	6.3/900	E	27,500	19HCP22 ^f

Test Picture Tubes

ROUND GLASS ENVELOPE				
53	6.3/600	E	20,000	5AXP4
RECTANGULAR GLASS ENVELOPE				
70	6.3/1800	E	27,500	1828P22
90	6.3/600	E	22,000	8XP4
90	6.3/900	E	27,500	1830P22
110	6.3/600	E	22,000	8YP4

§ E = Electrostatic; M = Magnetic

⊠ Cylindrical Faceplate

b Low G₂ Type

c Internal Magnetic Shield

d Faceplate Treated

e Low G₂ Type, Faceplate Treated

f Hi-Life type, features rare-earth red-emitting phosphor

g Integral Mounting Lugs

CATHODE-RAY TUBE, STORAGE TUBE, & MONOSCOPE CLASSIFICATION CHART

SPECIAL-PURPOSE KINESCOPIES					
Approx. Bulb Dia. Inches	Focus-ing Method	De-flec-tion Meth-od	Minimum Screen Size Inches	Maximum Anode Volts ^a	Tube Type
Monitor Types					
7	M	M	6-1/2	8,000	7CP4
7	E	M	6	12,000	7TP4
8b	E	M	7-13/16 ^b	14,000 ^c	8HP4
8b	E	M	7-3/4 ^b	22,000 ^c	8NP4
10	E	M	9-1/8	20,000	10SP4
17 ^b	E	M	15-9/16 ^b	22,000 ^c	17DWP4
21 ^b	E	M	20-1/4 ^b	22,000 ^c	21EYP4
Display Cathode-Ray Tube					
12 ^b	E	M	Has in-tegral protec-tive window	16,000	4557
Projection Types					
5	E	M	4-1/2 ^d	40,000 ^c	5AZP4
7	E	M	5 x 3-3/4 ^e	80,000 ^c	7NP4
7	E	M	5 x 3-3/4 ^e	80,000 ^c	7WP4
7	E	M	5 x 3-3/4 ^e	80,000 ^c	4486
View-Finder Type					
5	M	M	4-1/4	8,000	5FP4A
Transcriber Type					
5	E	M	4-1/4	27,000	5WP11
<p>E = Electrostatic.</p> <p>M = Magnetic.</p> <p>a Design-Center values unless otherwise noted.</p> <p>b Diagonal.</p> <p>c Absolute value.</p> <p>d Quality circle diameter.</p> <p>e Quality rectangle.</p>					

CATHODE-RAY TUBE, STORAGE TUBE, & MONOSCOPE CLASSIFICATION CHART

FLYING-SPOT CATHODE-RAY TUBES

Approx. Bulb Dia. Inches	Focusing Method	Deflection Method	Phosphor ^a	Maximum Anode Volts	Tube Type
Black-and-White Television Types					
5	E	M	P15	27,000 ^b	5WP15
5	E	M	P16	27,000 ^b	5ZP16
Color-Television Type					
5	E	M	P24	27,000 ^b	5AUP24

MONOSCOPES

Approx. Bulb Dia. Inches	Focusing Method	Deflection Method	Features	Maximum Anode Volts ^c	Tube Type
2	E	E	Customized metal stencil electrode pattern	2,500 ^d	4560
5	E	M	Indian Head Pattern	1,500 ^b	2F21
5	E	M	Pattern individually styled to customer requirements	1,500 ^b	1699

E = Electrostatic.

M = Magnetic.

a See sheet *Features of Fluorescent Screens*.

b Design-center value.

c Pattern-electrode voltage.

d Absolute-maximum value.

CATHODE-RAY TUBE, STORAGE TUBE, & MONOSCOPE CLASSIFICATION CHART

OSCILLOGRAPH TUBES			
Phosphor	Approx. Bulb Dia. Inches	Max. Anode Volts ^a	Tube Type
Electrostatic-Deflection & Focus Types			
P1	1	1,500	1EP1
P1	2	1,100	2AP1A
P1	2	2,500	2BP1
P1	2	600	902A
P1	3	1,500	3AP1A
P1	3	2,750	3AQP1
P1	3	2,000	3BP1A
P1	3	2,500	3KP1
P1	3	2,500	3RP1
P1	3	2,500	3RP1A
P1	3	2,500	3WP1
P1	5	2,000	5BP1A
P1	5	2,500	5UP1
P1	7	4,000	7UP1
P1	5	2,800 ^b	4499
P2	1	1,500	1EP2
P7	3	2,500	3KP7
P7	3	2,500	3RP7A
P7	5	2,500	5UP7
P11	1	1,500	1EP11
P11	2	2,500	2BP11
P11	3	2,500	3KP11
P11	3	2,500	3WP11
P11	5	2,500	5UP11
P31	5	2,500	5UP31
P31	7	4,000	7UP31

^a Design-center value.
^b Absolute-maximum value.

CATHODE-RAY TUBE, STORAGE TUBE, & MONOSCOPE CLASSIFICATION CHART

OSCILLOGRAPH TUBES (Cont'd)

Phosphor	Approx. Bulb Dia. Inches	Max. Post Accel- erator Volts	Tube Type
Electrostatic-Deflection & Focus Types With Post-Deflection Accelerator			
P1	3	4,000	3JP1
P1	5	6,000	5ABP1
P1	5	6,000	5ADP1
P1	5	4,000	5CP1A
P7	3	4,000	3JP7
P7	5	6,000 ^b	4510
P11	5	6,000	5ABP11
P11	5	4,000	5CP11A
P31	5	6,000	5ABP31
P31	5	6,000	5ADP31
P31	5	8,000 ^b	4489
P31	7	8,000 ^b	4490
P31	8	8,000 ^b	4491

Phosphor	Approx. Bulb Dia. Inches	Max. Anode Volts	Tube Type
Magnetic-Deflection & Focus Types			
P7	5	8,000	5FP7A
P7	7	8,000	7BP7A
P7	7	8,000	7MP7
b Absolute-maximum value.			

CATHODE-RAY TUBE, STORAGE TUBE, & MONOSCOPE CLASSIFICATION CHART

STORAGE TUBES		
Name	Description	Tube Type
Display	Ruggedized, 5"-diameter type having electrostatic-focus and deflection writing gun	2053
Display	Ruggedized, 10"-diameter type having electrostatic-focus and deflection writing gun	4412
Display	5"-diameter type having electrostatic-focus and magnetic-deflection writing gun	4454
Display	5"-diameter type having electrostatic-focus and deflection writing gun	6866
Display	5"-diameter type having electrostatic-focus and magnetic-deflection writing gun	7183A
Display	Ruggedized, 5"-diameter type having two electrostatic-focus and deflection writing guns	7268B
Display	5"-diameter type having electrostatic-focus and deflection writing gun	7315
Radechon	Single-beam barrier-grid type for digital data storage	6499
Radechon	Variant of 6499 for binary memory systems in computers	1858
Graphchon	Single-converter type with reading gun and writing gun	7539

RCA PICTURE TUBE INTERCHANGEABILITY GUIDE

Replacement Classification Keys

▲ Replacement information is based primarily on electrical and mechanical similarity of the picture-tube types covered. The technician should make certain that replacement is in accord with all safety precautions required by the TV receiver for picture-tube insulation or mechanical mounting.

A. RCA type does not require an external ion-trap magnet.

B. The ball-type anode contact must be replaced with cavity-type contact.

C. Neck length and/or overall length of RCA type is slightly greater.

D. Direct replacement.

E. The RCA replacement type is electrically interchangeable—Mechanical modifications to the receiver may be required.

F. The RCA replacement type has a 6.3-volt/600-milliampere heater. The receiver picture tube heater circuit must be modified to use this replacement type.

G. A conversion Kit (RCA Part No. 12B202) is available for RCA receivers.

H. The RCA replacement type is mechanically interchangeable—Electrical modifications to the receiver may be required.

J. The RCA replacement is directly interchangeable in most cases; however, in some cases the red cathode lead may have to be interchanged with the blue or green cathode leads to obtain satisfactory black-and-white tracking. Replacement information is packed with the tube.

K. Pin No. 6 (focusing electrode) of the RCA replacement must be connected to Pin No. 11 at the socket. The original tube did not require an external voltage for focus.

L. The RCA replacement type is electrically interchangeable — Mounting hardware may have to be modified to accept the replacement type. In some small-cabinet receivers, the replacement may not be feasible.

M. The RCA replacement type is electrically interchangeable — The receiver socket should be replaced by RCA Part No. 112579, Eby Sales Co. Part No. 49-13DD, or equivalent.

N. A conversion Kit (RCA Part No. 12B101) is available for RCA receivers.

P. External conductive coating must be grounded.

* Band around periphery of tube panel must be grounded and isolated from the ac line voltage.



RCA PICTURE TUBE INTERCHANGEABILITY GUIDE

Type To Be Replaced	★ Replaced By RCA Type	▲	Type To Be Replaced	★ Replaced By RCA Type	▲
11SP22 11WP22	C-11WP22	D	19HFP22	H-19GWP22 C-19GWP22/ 19EYP22	D
15AEP22 15AFP22 15AGP22	H-15AEP22 C-15AEP22	•D D	19HJP22 19HKP22	H-19HCP22/ 19HKP22 C-19HCP22/ 19HKP22	•D •D
15LP22	H-15LP22 C-15LP22	D D	19HNP22	H-19HNP22 C-19HNP22	•D •D
15NP22	H-15NP22 C-15NP22	•D •D	19HQP22	H-19GVP22 C-19GVP22/ 19EXP22	D D
15SP22	H-15AEP22 C-15AEP22	•D •D	19HRP22	H-19GWP22 C-19GWP22/ 19EYP22	D D
15TP22	H-15NP22 C-15NP22	•D •D	19HXP22	H-19HCP22/ 19HKP22 C-19HCP22/ 19HKP22	•D •D
15WP22	H-15LP22 C-15LP22	D D	19JBP22 19JDP22	H-19GVP22 C-19GVP22/ 19EXP22	D D
15XP22	H-15NP22 C-15NP22	•D •D	19JGP22	H-19JWP22 C-19JWP22	D D
17EZP22 17FAP22	H-17EZP22 C-17EZP22	•D •D	19JHP22	H-19GWP22 C-19GWP22/ 19EYP22	D D
19EXP22	H-19GVP22 C-19GVP22/ 19EXP22	D D	19JKP22	H-19GWP22 C-19GWP22/ 19EYP22	D D
19EYP22 19FMP22 19FXP22 19GSP22	H-19GWP22 C-19GWP22/ 19EYP22	D D	19JWP22	H-19JWP22 C-19JWP22	D D
19GVP22 19GVP22/ 19EXP22	H-19GVP22 C-19GVP22/ 19EXP22	D D	21AXP22 21AXP22A 21AXP22A/ 21AXP22	C-21AXP22A C-21CYP22A C-21FBP22 H-21GUP22 C-21GUP22/ 21FBP22A	D CN CJN CJN
19GWP22 19GWP22/ 19EYP22	H-19GWP22 C-19GWP22/ 19EYP22	D D	21CYP22 21CYP22A	C-21CYP22A C-21FBP22 H-21GUP22 C-21GUP22/ 21FBP22A	D J J J
19GXP22 19GYP22	H-19GVP22 C-19GVP22/ 19EZP22	C C	21FBP22 21FBP22A	C-21FBP22 H-21GUP22 C-21GUP22/ 21FBP22A	D J
19GZP22	H-19GWP22 C-19GWP22/ 19EYP22	D D			
19HBP22	H-19GWP22 C-19GWP22/ 19EYP22	D D			
19HCP22 19HCP22/ 19HKP22	H-19HCP22/ 19HKP22 C-19HCP22/ 19HKP22	•D •D			

★ See note on back of sheet 2 of this guide.

▲ See Replacement information in front of this guide.

RCA PICTURE TUBE INTERCHANGEABILITY GUIDE

Type To Be Replaced	★ Replaced By RCA Type	▲	Type To Be Replaced	★ Replaced By RCA Type	▲			
21FJP22	C-21FJP22	D	25AEP22	H-25YP22	D			
21FJP22A	H-21GVP22	J		C-25YP22/ 25BP22A	D			
21FKP22	C-21GVP22/ 21FJP22A	J		H-25XP22	D			
21GFP22	H-22JP22	L	25AFP22	C-25XP22/ 25AP22A	D			
21GLP22	C-22JP22	L		25AGP22	H-25AJP22	•D		
21GRP22			25AJP22	C-25AJP22	•D			
21GUP22	H-21GUP22	D	25ANP22	H-25XP22	D			
21GUP22/ 21FBP22A	C-21FBP22	D	25AP22	C-25XP22/ 25AP22A	D			
	C-21GUP22/ 21FBP22A	D	25AQP22					
21GVP22	H-21GVP22	D	25ASP22	H-25AJP22	•D			
21GVP22/ 21FJP22A	C-21FJP22	D				25AWP22	C-25AJP22	•D
	C-21GVP22/ 21FJP22A	D				25AXP22		
21GWP22	H-22JP22	L	25AZP22					
	C-22JP22	L						
21GXP22	H-21GVP22	D	25BMP22	H-25XP22	D			
21GYP22	C-21FJP22	D		C-25XP22/ 25AP22A	D			
	C-21GVP22/ 21FJP22A	D		25BP22	H-25YP22	D		
22ADP22	H-22UP22	•D	25BP22A	C-25YP22/ 25BP22A	D			
22AGP22	C-22UP22	•D	25CP22	H-25XP22	D			
22AHP22			25CP22A	C-25XP22/ 25AP22A	D			
22JP22	H-22JP22	D						
	C-22JP22	D	25FP22	H-25YP22	D			
			25FP22A	C-25YP22/ 25BP22A	D			
22KP22	H-22KP22	D						
	C-22JP22	D	25GP22	H-25XP22	D			
22LP22	H-22JP22	D	25GP22A	C-25XP22/ 25AP22A	D			
22QP22	C-22JP22	D						
22RP22	H-22KP22	D	25RP22	H-25YP22	D			
	C-22KP22	D		C-25YP22/ 25BP22A	D			
22SP22	H-22JP22	D						
	C-22JP22	D	25SP22	H-25XP22	D			
22UP22	H-22UP22	•D		C-25XP22/ 25AP22A	D			
22XP22	C-22UP22	•D						
22YP22	H-22JP22	D	25VP22	H-25XP22	D			
	C-22JP22	D		C-25XP22/ 25BP22A	D			
23EGP22	C-23EGP22	D	25WP22					
23EGP22A	C-23EGP22A		25XP22	H-25XP22	D			
25ABP22	H-25XP22	D	25XP22/ 25AP22A	C-25XP22/ 25AP22A	D			
	C-25XP22/ 25AP22A	D	25YP22	H-25YP22	D			
			25YP22/ 25BP22A	C-25YP22/ 25BP22A	D			
25ADP22	H-25AJP22	•D						
	C-25AJP22	•D						

★ See note on back of sheet 2 of this guide.

▲ See Replacement information in front of this guide.



**Electronic
Components**

INTERCHANGEABILITY
GUIDE 2 8-70

RCA PICTURE TUBE INTERCHANGEABILITY GUIDE

Type To Be Replaced	★ Replaced By RCA Type	▲	Type To Be Replaced	★ Replaced By RCA Type	▲
25ZP22	H-25XP22 C-25XP22/ 25AP22A	D D	490BGB22	H-19GVP22 C-19GVP22/ 19EXP22	D D D
370AB22	H-15NP22	• D	490BHB22	H-19GWP22 C-19GWP22/ 19EYP22	D D D
370CB22	C-15NP22	• D	490BNB22	H-19JWP22 C-19JWP22	D D
490AB22	H-19GVP22	J	490BRB22	H-19GWP22 C-19GWP22/ 19EYP22	D D D
490ACB22	C-19GVP22/ 19EXP22	J	490BVB22	H-19JWP22	D
490ADB22	H-19GWP22	J	490BXB22	C-19JWP22	D
490AEB22	C-19GWP22/ 19EYP22	J	490CB22	H-19GVP22	J
490AGB22	H-19GVP22 C-19GVP22/ 19EXP22	J J J	490DB22	C-19GVP22/ 19EXP22	J J
490AHB22	H-19GVP22 C-19GVP22/ 19EXP22	J J J	490EB22	19EXP22	J
490AHB22A	H-19GVP22 C-19GVP22/ 19EXP22	D D D	490EB22A		
490AJB22	H-19GWP22	D	490FB22		
490AJB22A	C-19GWP22/ 19EYP22	D D	490GB22		
490AKB22	H-19GVP22	J	490HB22	H-19GVP22	D
490ALB22	C-19GVP22/ 19EXP22	J J	490JB22	C-19GVP22/ 19EXP22	D D
490AMB22	19EXP22	J	490JB22A	19EXP22	D
490ANB22			490KB22	H-19GVP22	J
490ARB22	H-19GWP22 C-19GWP22/ 19EYP22	J J J	490KB22A	C-19GVP22/ 19EXP22	J J
490ASB22	H-19GWP22 C-19GWP22/ 19EYP22	D D D	490LB22	19EXP22	J
490BAB22	H-19GVP22 C-19GVP22/ 19EXP22	D D D	490MB22		
490BCB22	H-19GWP22 C-19GWP22/ 19EYP22	D D D	490NB22	H-19GWP22	J
490BDB22	H-19GWP22 C-19GWP22/ 19EYP22	J J J	490RB22	C-19GWP22/ 19EYP22	J J
			490SB22	19EYP22	J
			490TB22		
			490UB22	H-19GVP22 C-19GVP22/ 19EXP22	J J J
			490VB22	H-19GWP22 C-19GWP22/ 19EYP22	J J J
			490WB22	H-19GVP22 C-19GVP22/ 19EXP22	J J J
			490XB22	H-19GWP22	J
			490YB22	C-19GWP22/ 19EYP22	J J
			490ZB22	19EYP22	J

The type to be replaced may have a manufacturer's coding prefix such as AN, C, CR, H, HR, OC, RE, REA, etc. Since these prefixes do not affect the electrical characteristics or interchangeability of the type, the prefixes have been omitted from type numbers in this column.

▲ See *Replacement information* in front of this guide.



**Electronic
Components**

INTERCHANGEABILITY
GUIDE 2

RCA PICTURE TUBE INTERCHANGEABILITY GUIDE

Type To Be Replaced	★ Replaced By RCA Type	▲	Type To Be Replaced	★ Replaced By RCA Type	▲
Black & White Picture Tubes					
7JP4	7JP4	D	16BQP4	16CMP4	•C
8DP4	8DP4	D	16CHP4	16ATP4	•E
9AEP4	9AEP4	•D	16BVP4	16CMP4A	•E
9WP4	9WP4	•D	16BWP4	16BGP4	•D
10ATP4	10ATP4	D	16CAP4		
11AP4	11HP4A	•D	16CEP4	16CMP4A	•D
11BP4			16CHP4	16CHP4A	•D
11CP4	11CP4	D	16CHP4A		
11GP4	11GP4	•D	16CJP4	16CMP4A	•D
11HP4	11HP4A	•D	16CMP4		
11HP4A			16CMP4A		
12BNP4	12BNP4A	•D	16CTP4	16BGP4	•C
12BNP4A			16CUP4	16CMP4A	•C
12CFP4	12CNP4	•D	16CVP4	16CHP4A	•CE
12CGP4	12BNP4A	•D	16KP4	16RP4B	A
12CNP4	12CNP4	•D	16KP4A		
12DEP4	12DEP4	•D	16QP4	16RP4B	AP
12DFP4	12DFP4	•D	16RP4	16RP4B	A
12DSP4	12DSP4	D	16RP4/ 16KP4		
14NP4	14WP4	A	16RP4A		
14NP4A			16RP4A/ 16KP4A		
14RP4			16RP4B	16RP4B	D
14RP4A			16TP4	16TP4	D
14SP4			16UP4	16RP4B	ACP
14WP4	14WP4	D	16XP4	16RP4B	AP
14WP4/ 14ZP4			17AP4	17BP4D	ACP
14ZP4			17ATP4	17BJP4	A
14ZP4/ 14WP4			17ATP4/ 17AVP4		
16ASP4	16CMP4A	•E	17ATP4A		
16AXP4			17ATP4A/ 17AVP4A		
16AYP4	16BGP4	•E	17AVP4		
16BFP4	16CMP4A	•C	17AVP4/ 17ATP4		
16BGP4	16BGP4	•D	17AVP4A		
16BKP4	16CHP4A	•C	17AVP4A/ 17ATP4A		
16BMP4	16BGP4	•CE			

▲ See Replacement information in front of this guide.

RCA PICTURE TUBE INTERCHANGEABILITY GUIDE

Type To Be ★ Replaced	Replaced By RCA Type	▲	Type To Be ★ Replaced	Replaced By RCA Type	▲
17BJP4	17BJP4	D	17FP4		
17BP4	17BP4D	AP	17FP4A		
17BP4A	17BP4D	A	17HP4		
17BP4B			17HP4/ 17RP4	17HP4C	A
17BP4C			17HP4A		
17BP4D	17BP4D	D	17HP4B		
17BRP4	17DSP4	A	17HP4B/ 17RP4C		
17BUP4	17BJP4	A	17HP4C	17HP4C	D
17BZP4	17DSP4	D	17JP4	17BP4D	A
17BZP4/ 17CAP4/ 17CKP4			17KP4	17HP4C	AK
17BZP4/ 17CAP4/ 17CKP4/ 17BRP4			17KP4A		
17CAP4			17LP4	17LP4B	A
17CBP4	17BJP4	A	17LP4/ 17VP4		
17CFP4	17CFP4	D	17LP4A		
17CKP4	17DSP4	D	17LP4A/ 17VP4B		
17CLP4	17BJP4	AP	17LP4B	17LP4B	D
17CTP4	17EFP4	D	17QP4	17QP4B	A
17CWP4	17DSP4	D	17QP4A		
17CYP4	17CFP4	D	17QP4B	17QP4B	D
17DAP4	17DAP4	D	17RP4	17HP4C	A
17DHP4	17EFP4	P	17RP4C		
17DKP4	17DSP4	C	17SP4	17LP4B	AK
17DLP4	17DSP4	D	17UP4	17QP4B	A
17DQP4	17DQP4	D	17VP4	17LP4B	A
17DRP4	17DRP4	D	17VP4/ 17LP4		
17DSP4	17DSP4	D	17VP4B		
17DTP4	17DSP4	C	17YP4	17QP4B	A
17DXP4	17DXP4	D	19ABP4	19ABP4	D
17DZP4			19ACP4	19CHP4	D
17EAP4	17HP4C	AK	19ADP4	19AVP4	D
17EBP4	17EFP4	D	19AFP4	19AFP4	D
17EFP4	17EFP4	D	19AGP4	19AVP4	C
17EMP4	17EMP4	•D	19AHP4	19AYP4	D
17EWP4	17EWP4	•D	19AJP4	19AJP4	D
17FCP4	17FCP4	•D	19AKP4	19AVP4	D
			19ANP4	19AYP4	C
			19ARP4	19AFP4	D

▲ See Replacement information in front of this guide.

RCA PICTURE TUBE INTERCHANGEABILITY GUIDE

Type To Be Replaced	★ Replaced By RCA Type	▲	Type To Be Replaced	★ Replaced By RCA Type	▲
19ATP4	19AFP4	C	19DHP4	19DSP4	•D
19AUP4	19AFP4	D	19DKP4	19DRP4	•E
19AVP4	19AVP4	D	19DLP4	19CHP4	D
19AWP4	19AYP4	C	19DNP4	19DRP4	•E
19AXP4	19AYP4	D	19DQP4	19DQP4	•D
19AYP4			19DRP4	19DRP4	•D
19AZP4	19AVP4	D	19DSP4	19DSP4	•D
19BDP4	19BDP4	D	19DTP4	19DQP4	•C
19BHP4	19AVP4	D	19DUP4	19DUP4	•D
19BLP4	19AVP4	C	19DWP4	19DQP4	•D
19BMP4	19AFP4	C	19EAP4	19FEP4B	•D
19BRP4	19DRP4	•E	19EBP4	19EBP4	•D
19BSP4	19AVP4	C	19EDP4	19DRP4	•D
19BTP4			19EFP4	19DSP4	•D
19BVP4	19AVP4	D	19EGP4	19EGP4	•D
19BWP4	19AYP4	D	19EHP4	19DRP4	•D
19BXP4	19AYP4	E	19EHP4A		
19CAP4	19AVP4	C	19EJP4	19FEP4B	•D
19CDP4	19CXP4	D	19ELP4	19AVP4	D
19CFP4	19CHP4	CE	19EMP4	19EBP4	•C
19CHP4	19CHP4	D	19ENP4	19FEP4B	•D
19CJP4	19AVP4	D	19ENP4A		
19CKP4	19CHP4	E	19ERP4	19DRP4	•D
19CLP4	19BDP4	D	19ESP4	19DSP4	•D
19CMP4	19CMP4	D	19EUP4	19DRP4	•D
19CMP4A			19EVP4	19DQP4	•D
19CQP4	19CXP4	D	19EWP4		
19CRP4	19BDP4	D	19EZP4	19EZP4	•D
19CSP4	19CHP4	D	19FBP4	19EGP4	•D
19CUP4	19CMP4	D	19FCP4	19DQP4	•D
19CXP4	19CXP4	D	19FCP4A		
19CYP4	19AVP4	C	19FDP4		
19CZP4	19DQP4	•E	19FEP4	19FEP4B	•D
19DAP4			19FEP4A		
19DCP4	19DRP4	•D	19FEP4B	19FEP4B	•D
19DEP4	19AVP4	E	19FJP4	19DQP4	•D
19DFP4	19CHP4	D	19FJP4A		
			19FLP4	19FLP4	•D
			19FSP4	19FEP4B	•D
			19FTP4	19FLP4	•D

▲ See Replacement information in front of this guide.

RCA PICTURE TUBE INTERCHANGEABILITY GUIDE

Type To Be Replaced	★ Replaced By RCA Type	▲	Type To Be Replaced	★ Replaced By RCA Type	▲
19FWP4	19AYP4	D	21AFP4	21YP4B	AP
19GAP4	19GAP4	*D	21ALP4	21CBP4A	AP
19GBP4	19DQP4	*E	21ALP4A		
19GEP4	19GEP4A	*D	21ALP4B		
19GEP4A			21ALP4B/ 21ALP4A		
19GFP4			21AMP4	21AMP4B	A
19GHP4	19DUP4	*C	21AMP4A		
19GJP4	19DQP4	*D	21AMP4B	21AMP4B	D
19GJP4A			21ANP4	21CBP4A	AP
19GNP4	19DRP4	*D	21ANP4A		
19GRP4	19DQP4	*D	21AP4	21ZP4C	G
19GTP4	19FEP4B	*C	21AQP4	21AMP4B	AP
19XP4	19AVP4	D	21AQP4A		
19YP4	19AVP4	C	21ASP4	21XP4B	AP
19ZP4	19AVP4	D	21ATP4	21CBP4A	AP
20CP4	20DP4D	ACP	21ATP4A		
20CP4A	20DP4D	AC	21ATP4A/ 21ATP4		
20CP4B	20DP4D	ACP	21ATP4B		
20CP4C			21AUP4	21AVP4C	A
20CP4D	20DP4D	AP	21AUP4A		
20DP4A			21AUP4B		
20DP4A/ 20CP4A	20DP4D	A	21AUP4B/ 21AUP4A		
20DP4B	20DP4D	AP	21AUP4C	21AVP4C	D
20DP4C			21AVP4	21AVP4C	A
20DP4C/ 20CP4D	20DP4D	A	21AVP4/ 21AUP4		
20DP4D	20DP4D	D	21AVP4A		
20RP4	20RP4	*D	21AVP4B		
20SP4	20SP4	*D	21AVP4B/ 21AVP4A		
20TP4	20TP4	*D	21AVP4B/ 21AUP4B		
20XP4			21AUP4A		
20YP4	20SP4	*D	21AUP4A		
20ZP4	20SP4	*D	21AVP4C	21AVP4C	D
21ACP4	21AMP4B	A	21AWP4	21AWP4A	A
21ACP4/ 21AMP4			21AWP4A	21AWP4A	D
21ACP4A			21AYP4	21XP4B	A
21ACP4A/ 21AMP4A			21BAP4	21CBP4A	D
21ACP4A/ 21AMP4A			21BCP4	21YP4B	C
21ACP4A/ 21BSP4/ 21AMP4A			21BDP4	21AVP4C	D
			21BNP4	21CBP4A	D

▲ See Replacement information in front of this guide.



Electronic Components

INTERCHANGEABILITY GUIDE 4

RCA PICTURE TUBE INTERCHANGEABILITY GUIDE

Type To Be Replaced	★ Replaced By RCA Type	▲	Type To Be Replaced	★ Replaced By RCA Type	▲
21BSP4	21AMP4B	A	21EP4A	21EP4C	A
21BTP4	21CBP4A	A	21EP4B		
21CBP4	21CBP4A	D	21EP4C	21EP4C	D
21CBP4A			21EQP4	21EMP4/ 21EQP4	D
21CBP4A/ 21CBP4/ 21CMP4			21ETP4		
21CBP4B			21EVP4	21FDP4	CF
21CEP4	21EMP4/ 21EQPA	D	21FAP4	21EMP4/ 21EQP4	D
21CEP4A			21FDP4	21FDP4	D
21CMP4	21CBP4A	A	21FLP4	21CBP4A	D
21CQP4	21CQP4	D	21FP4	21FP4D	AP
21CUP4	21AMP4B	A	21FP4A	21FP4D	A
21CVP4	21CBP4A	D	21FP4C		
21CWP4	21CBP4A	A	21FP4D	21FP4D	D
21CXP4	21DSP4	D	21FVP4	21FVP4	*D
21CZP4	21EMP4/ 21EQP4	A	21FWP4		
21DAP4	21DEP4A	D	21FZP4		
21DEP4			21GAP4	21GAP4A	*D
21DEP4A			21GAP4A		
21DEP4A/ 21DEP4/ 21CZP4			21KP4	21FP4D	AK
21DFP4	21EMP4/ 21EQP4	D	21KP4A		
21DHP4	21DHP4	D	21MP4	21YP4B	E
21DLP4	21DLP4	D	21WP4	21WP4B	A
21DMP4	21EMP4/ 21EQP4	D	21WP4A		
21DNP4	21CBP4A	AP	21WP4B	21WP4B	D
21DQP4	21DLP4	D	21XP4	21XP4B	A
21DRP4	21CBP4A	D	21XP4A		
21DSP4	21DSP4	D	21XP4B	21XP4B	D
21EAP4	21FDP4	F	21YP4	21YP4B	A
21EDP4	21EMP4/ 21EQP4	D	21YP4A		
21EMP4			21YP4B	21YP4B	D
21EMP4/ 21EQP4			21ZP4	21ZP4C	AP
21EP4	21EP4C	AP	21ZP4A	21ZP4C	A
			21AP4B		
			21ZP4C	21ZP4C	D
			23ACP4	23YP4	D
			23AFP4		
			23AGP4	23CP4	C
			23AHP4	23AHP4/ 23FP4A	D
			23AKP4		C

▲ See Replacement information in front of this guide.

RCA PICTURE TUBE INTERCHANGEABILITY GUIDE

Type To Be Replaced	★ Replaced By RCA Type	▲	Type To Be Replaced	★ Replaced By RCA Type	▲
23ALP4	23CQP4	D	23DLP4	23ENP4	*C
23ANP4	23BKP4	D	23DLP4A		
23ARP4	23ARP4	D	23DNP4	23BKP4	D
23ASP4	23ASP4	D	23DP4	23CP4	C
23ATP4	23BKP4	D	23DQP4	23BKP4	M
23AUP4	23AHP4/	D	23DSP4	23ENP4	*M
23AVP4	23CP4	C	23DSP4A		
23AWP4	23BJP4	C	23DTP4	23EKP4	*D
23BAP4	23CP4	C	23DXP4	23CP4	D
23BDP4	23YP4	D	23DYP4	23ETP4	*P
23BFP4	23FP4A	C	23DZP4	23EQP4	*D
23BGP4	23BGP4	D	23ECP4	23ENP4	*E
23BHP4			23EDP4	23EKP4	*E
23BJP4	23BJP4	D	23EHP4	23EKP4	*D
23BKP4	23BKP4	D	23EKP4		
23BLP4			23ELP4		
23BMP4	23YP4	D	23EMP4		
23BNP4	23CP4	D	23ENP4	23ENP4	*D
23BP4	23CP4	C	23EP4	23EP4	D
23BQP4	23BQP4	D	23EQP4	23EQP4	*D
23BTP4	23YP4	D	23ESP4	23HFP4A	*D
23BVP4			23ETP4	23ETP4	*D
23BWP4			23EWP4	23EQP4	*D
23BXP4	23EKP4	*E	23EWP4A		
23BZP4	23CGP4	D	23EYP4	23EYP4	D
23CBP4	23BQP4	D	23EZP4	23EYP4	*D
23CEP4	23ARP4	D	23FBP4	23ENP4	*D
23CGP4	23CGP4	D	23FCP4	23GJP4A	*D
23CP4	23CP4	D	23FDP4		
23CP4A			23FEP4	23ENP4	*D
23CQP4	23CQP4	D	23FHP4	23GJP4A	*D
23CUP4	23CP4	C	23FJP4	23ETP4	*D
23CZP4	23AHP4	D	23FLP4	23EKP4	*D
23DAP4	23DAP4	D	23FMP4	23HFP4A	*D
23DBP4	23DBP4	D	23FP4	23FP4A	D
23DKP4	23EKP4	*D	23FP4A		
			23FRP4	23FRP4	*D
			23FSP4	23FSP4	*D
			23FVP4	23HFP4A	*D
			23FVP4A		

▲ See Replacement information in front of this guide.



Electronic Components

INTERCHANGEABILITY GUIDE 5

RCA PICTURE TUBE INTERCHANGEABILITY GUIDE

Type To Be Replaced	★ Replaced By RCA Type	▲	Type To Be Replaced	★ Replaced By RCA Type	▲
23FZP4	23GSP4	*D	23XP4	23YP4	D
23GBP4	23HFP4A	*D	23YP4		
23GEP4	23ENP4	*D	24ADP4	24CP4B	A
23GFP4	23HGP4	*D	24ADP4/ 24VP4A/ 24CP4A/ 24TP4		
23GJP4	23GJP4A	*D	24AEP4	24AEP4	D
23GJP4A			24AHP4	24AHP4	D
23GP4	23CP4	D	24ALP4	24AHP4	D
23GSP4	23GSP4	*D	24ANP4	24AEP4	A
23GTP4	23ETP4	*D	24AUP4	24AUP4	D
23GUP4	23FRP4	*D	24AVP4	24BEP4	F
23GVP4	23HUP4A	*D	24BEP4	24BEP4	D
23GWP4	23GWP4	*D	24CP4	24CP4B	D
23GXP4	23GSP4	*D	24CP4A	24CP4B	A
23GZP4	23EKP4	*E	24CP4B	24CP4B	D
23HFP4	23HFP4A	*D	24DP4	24AEP4	A
23HFP4A			24DP4A		
23HGP4	23HGP4	*D	24DP4A/ 24YP4		
23HLP4	23GSP4	*D	24QP4	24CP4B	AP
23HP4	23CP4	D	24TP4	24CP4B	A
23HQP4	23HGP4	*D	24VP4		
23HRP4	23HWP4A	*C	24VP4A		
23HSP4			24XP4	24CP4B	AP
23HUP4	23HUP4A	*D	24YP4	24AEP4	A
23HUP4A			24ZP4	24EAP4	D
23HWP4	23HWP4A	*D	230RB4	9WP4	*D
23HWP4A	23HWP4A	*D	310AVB4	12CNP4	*D
23XHP4	23HFP4A	*D	470ACB4	19AYP4	D
23HYP4	23JEP4	*D	500KB4	20TP4	*D
23JAP4	23GJP4A	*D	SG10FP4A	10FP4A	D
23JBP4	23FSP4	*C	SG14WP4	14WP4	D
23JEP4	23JEP4	*D	SG16KP4A	16RP4B	D
23JGP4	23FRP4	*D	SG17BJP4	17BJP4	D
23JHP4	23HFP4A	*D	SG17BP4B	17BP4D	D
23JLP4	23HUP4A	*D	SG17CKP4	17DSP4	D
23JP4	23JP4	D	SG17HP4B	17HP4C	D
23KP4	23FP4A	C	SG17LP4A	17LP4B	D
23KP4A			SG17QP4A	17QP4B	D
23LP4	23ETP4	*D	SG20CP4D	20DP4D	C
23MP4	23FP4A	D	SG21ACP4A	21AMP4B	D
23MP4/ 23MP4A/ 23WP4			SG21AUP4B	21AVP4C	D
23MP4A			SG21AWP4	21AWP4A	D
23NP4	23NP4	D	SG21DEP4A	21EMP4/ 21EQP4	D
23QP4	23CP4	D	SG21EP4B	21EP4C	D
23TP4	23YP4	D	SG21FLP4	21CBP4A	D
23UP4	23BQP4	D	SG21FP4C	21FP4D	D
23WP4	23FP4A	D	SG21WP4A	21WP4B	D

▲ See Replacement information in front of this guide.

RCA PICTURE TUBE INTERCHANGEABILITY GUIDE

Type			Type		
To Be Replaced	★ Replaced By RCA Type	▲	To Be Replaced	★ Replaced By RCA Type	▲
SG21XP4A	21XP4B	D	SG24AEP4	24AEP4	D
SG21YP4A	21YP4B	D	SG24CP4A	24CP4B	D
SG21ZP4B	21ZP4C	D			

▲ See Replacement information in front of this guide.

Safety Precautions For Color Picture Tubes

WARNING

X-Radiation:

Operation of the referenced color picture tube at abnormal conditions which exceed the 0.5 mR/h isodose-rate curve shown for this tube may produce soft X-rays which may constitute a health hazard on prolonged exposure at close range unless adequate external shielding is provided. Therefore, precautions must be exercised during servicing of TV receivers employing this tube to assure that the anode voltage and other tube voltages are adjusted to the recommended values so that the Design-Maximum Ratings will not be exceeded.

This color picture tube incorporates integral X-radiation shielding and must be replaced with a tube of the same type number or an RCA recommended replacement to assure continued safety.

Implosion Protection:

This picture tube employs integral implosion protection and must be replaced with a tube of the same type number or an RCA recommended replacement to assure continued safety.

Shock Hazard:

The high voltage at which the tube is operated may be very dangerous. Design of the TV receiver should include safeguards to prevent the user from coming in contact with the high voltage. Extreme care should be taken in the servicing or adjustment of any high-voltage circuit.

Caution must be exercised during the replacement or servicing of the picture tube since a residual electrical charge may be contained on the high-voltage capacitor formed by the external and internal conductive coatings of the picture tube funnel. To remove any undesirable residual high-voltage charges from the picture tube, "bleed off" the charge by shorting the anode contact button, located in the funnel of



Safety Precautions For Color Picture Tubes

the picture tube, to the external conductive coating before handling the tube. Discharging the high voltage to isolated metal parts such as cabinets and control brackets may produce a shock hazard.

Tube Handling:

Picture tubes should be kept in the shipping box or similar protective container until just prior to installation. Wear heavy protective clothing, including gloves and safety goggles with side shields, in areas containing unpacked and unprotected tubes to prevent possible injury from flying glass in the event a tube breaks. Handle the picture tube with extreme care. Do not strike, scratch or subject the tube to more than moderate pressure. Particular care should be taken to prevent damage to the seal area.

The equipment manufacturer should provide a warning label in an appropriate position on the equipment to advise the serviceman of all safety precautions.



FEATURES OF FLUORESCENT SCREENS

The fluorescent screens of the cathode-ray tubes covered in this Section are identified according to phosphor number, e.g., P1, P2, P4, P5, P7, etc.

Phosphor P1 produces a brilliant spot having yellowish-green fluorescence and medium persistence. Types having this phosphor are particularly useful for general oscillographic applications in which recurrent-wave phenomena are to be observed visually.

Phosphor P2 is a medium-persistence screen which exhibits yellowish-green fluorescence and phosphorescence. The phosphorescence may persist for over a minute under conditions of adequate excitation and low-ambient light. Types utilizing this phosphor are particularly useful for observing either low- or medium-speed non-recurring phenomena.

Phosphor P4 is a highly efficient screen having white fluorescence and medium-short persistence. Types having this phosphor are of particular interest for television picture tubes.

Phosphor P5 produces a highly actinic spot having blue fluorescence and medium-short persistence. Types having this phosphor are especially useful in photographic applications involving film moving at very high speeds.

Phosphor P7 is a very long-persistence, cascade (two-layer) screen. During excitation by the electron beam, this phosphor produces a purplish-blue fluorescence. After excitation, the screen exhibits a yellowish-green phosphorescence which persists for several minutes. Types having this phosphor are particularly useful where either extremely low-speed recurrent phenomena or medium-speed non-recurrent phenomena are to be observed.

Phosphor P11 produces a brilliant actinic spot of blue fluorescence and medium-short persistence to permit its use in all photographic applications except those in which film moves at high speed. P11 screens, because of their unusually high brightness characteristic, may also be used for visual observation of phenomena.

Phosphor P12 is a long-persistence phosphor which exhibits both yellowish-orange fluorescence and phosphorescence. Types utilizing this phosphor are particularly useful for observing low- and medium-speed recurring phenomena.

Phosphor P14 is a long-persistence cascade (two-layer) screen. During excitation by the electron beam, this phosphor exhibits purplish-blue fluorescence. After excitation, it exhibits a yellowish-orange phosphorescence which persists for a little over a minute. Types utilizing this phosphor are particularly useful for observing either low- and medium-speed non-recurring phenomena or high-speed recurring phenomena.



FEATURES OF FLUORESCENT SCREENS

Phosphor P15 has radiation in the visible green region and in the invisible near-ultraviolet region. The ultraviolet radiation has short persistence which is appreciably shorter than that of the visible radiation. This phosphor finds application in flying-spot cathode-ray tubes.

Phosphor P16 has violet as well as near-ultraviolet fluorescence and phosphorescence with very short persistence. This phosphor has a stable, exponential decay characteristic and is particularly useful for the high-speed scanning requirements of a flying-spot video-signal generator.

Phosphor P20 has high luminous efficiency, yellow-green fluorescence and medium-short persistence. The screen may be used in applications requiring relatively short persistence and good visual efficiency.

Phosphor P22 is the designation for three separate phosphors used in combination in a color picture tube. The separate phosphors are blue, green, and red, respectively. The persistence of the group phosphorescence is classified as medium.

Phosphor P24 is a short-persistence phosphor with green fluorescence and phosphorescence. Its spectral-energy emission characteristic has sufficient range to provide useable energy over the visible spectrum required for generating color signals from color transparencies.



SPECTRAL-ENERGY EMISSION CHARACTERISTIC OF PHOSPHOR P1

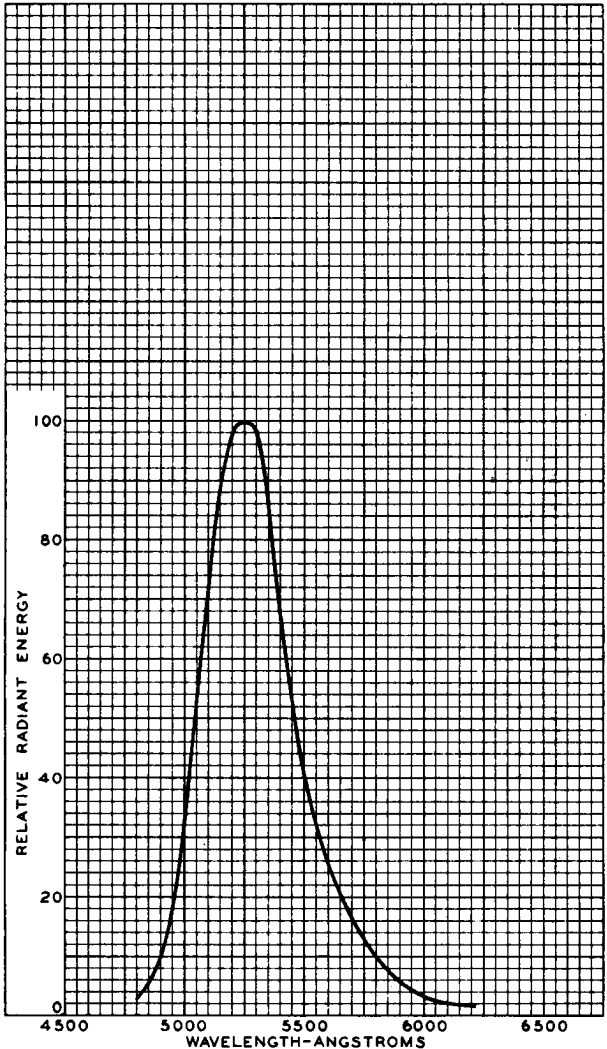

DEC.14,1948

TUBE DIVISION
RADIO CORPORATION OF AMERICA, HARRISON, NEW JERSEY

92CM-5372R1



PERSISTENCE CHARACTERISTIC OF PHOSPHOR P1

CURVE IS ESSENTIALLY INDEPENDENT
OF TUBE OPERATING VALUES

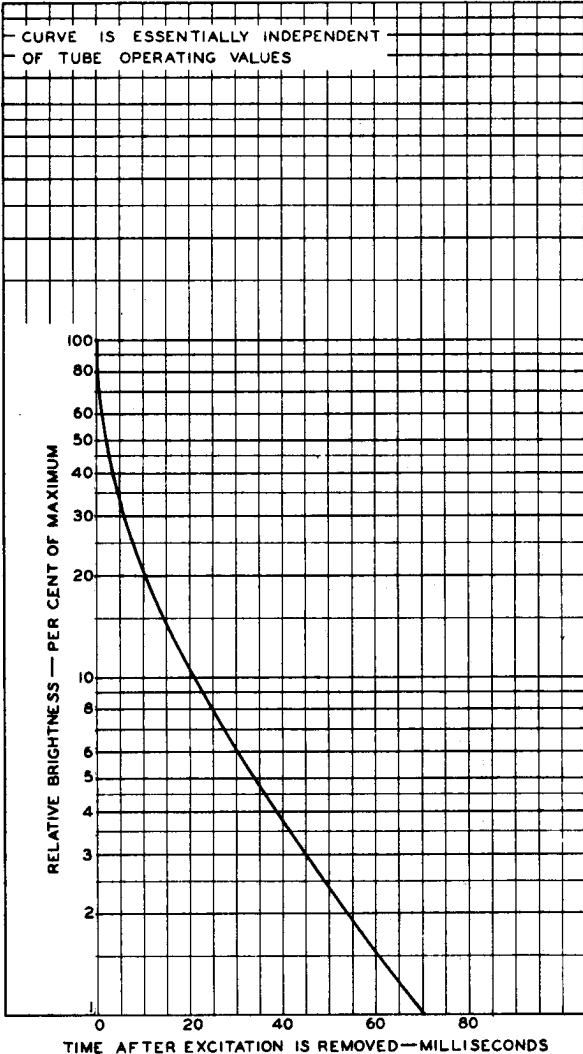



SPECTRAL-ENERGY EMISSION CHARACTERISTIC OF PHOSPHOR P2

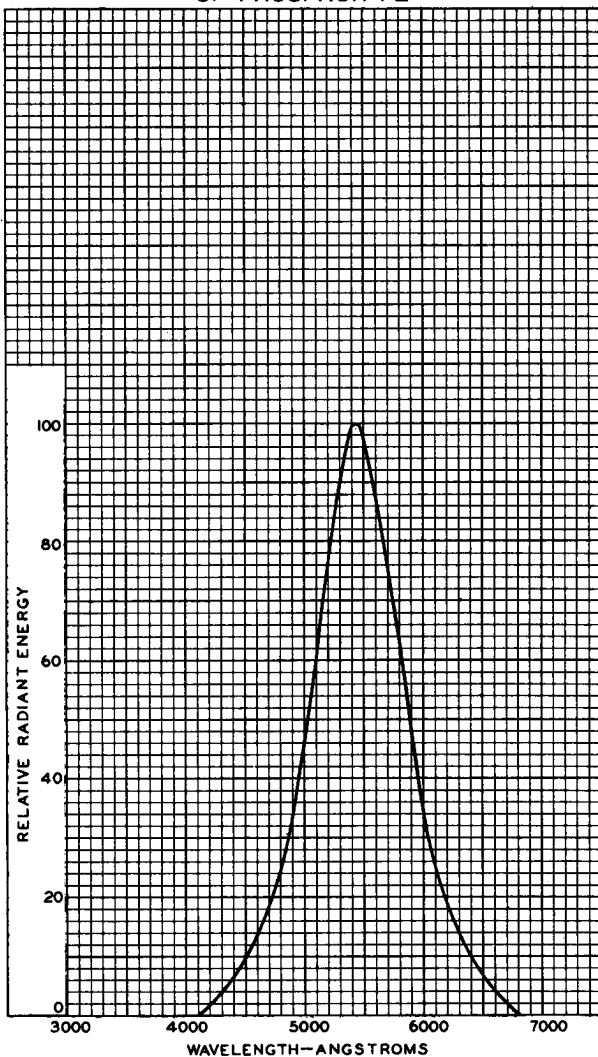



PERSISTENCE CHARACTERISTIC OF PHOSPHOR P2

Subdivisions are 2, 4, 6, 8

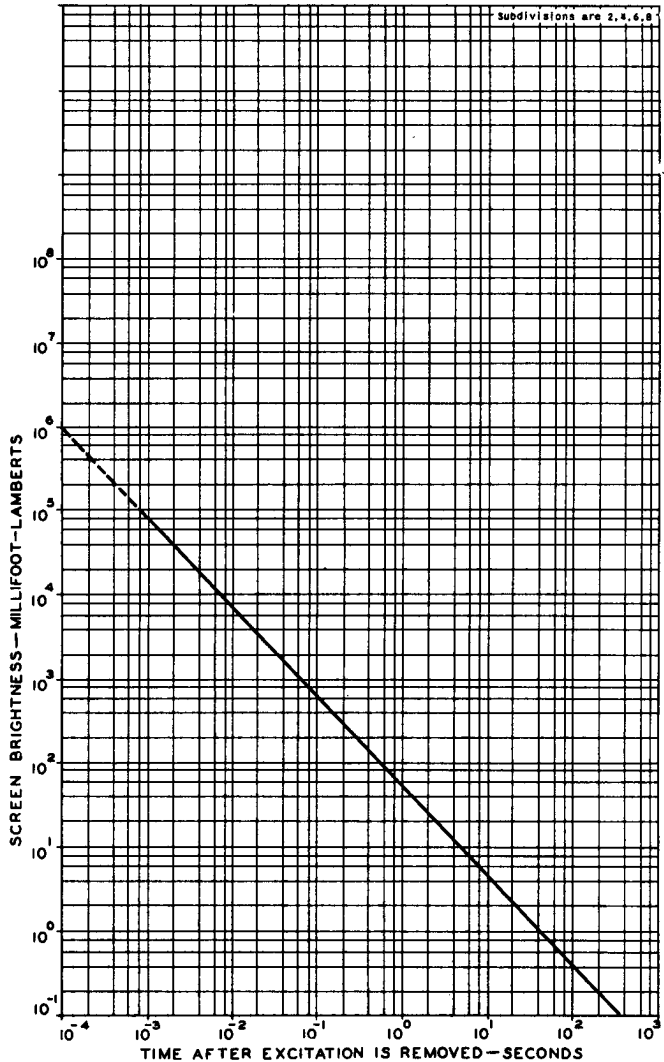

TUBE DIVISION

92CM-7321

RADIO CORPORATION OF AMERICA, HARRISON, NEW JERSEY



SPECTRAL-ENERGY EMISSION CHARACTERISTIC OF PHOSPHOR P4 SULFIDE TYPE

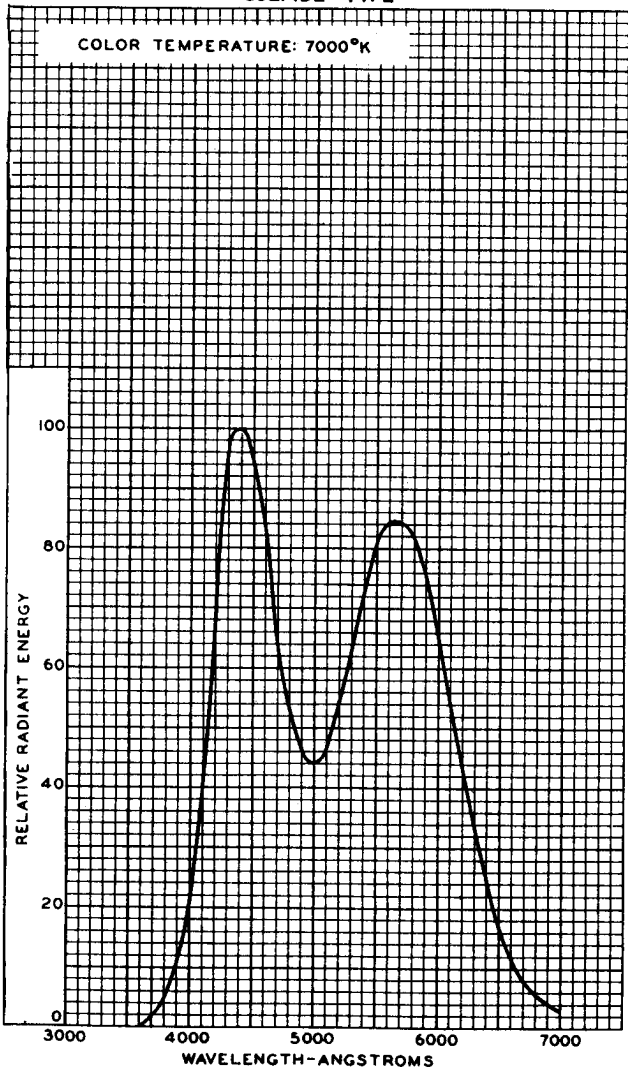



PERSISTENCE CHARACTERISTIC OF PHOSPHOR P4 SULFIDE TYPE

FOR KINESCOPIES

The persistence of the phosphorescence is such that its brightness does not exceed 7 per cent of the peak value in 33 milliseconds after excitation is removed.

FOR OSCILLOGRAPH TUBES

The persistence characteristics of the phosphorescence are the same as those shown for the P11 phosphor.



SPECTRAL-ENERGY EMISSION CHARACTERISTIC OF PHOSPHOR №4 SILICATE-SULFIDE TYPE

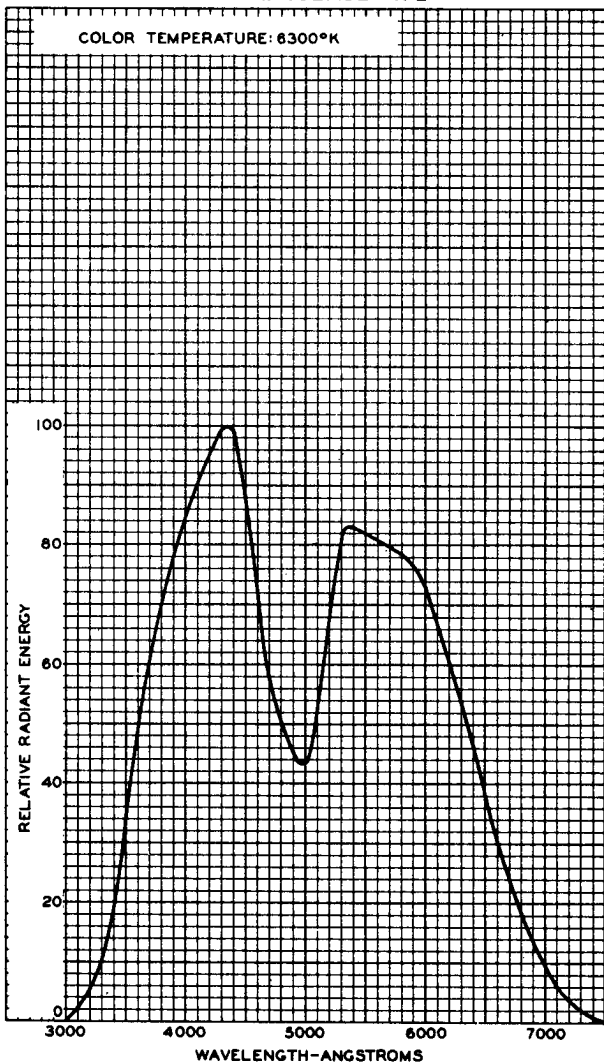

MARCH 6, 1950

TUBE DEPARTMENT
RADIO CORPORATION OF AMERICA, HARRISON, NEW JERSEY

92CM-7458



**PERSISTENCE CHARACTERISTIC
OF PHOSPOR № 4
SILICATE-SULFIDE TYPE**

The persistence of the phosphorescence is such that its brightness does not exceed 7 per cent of the peak value in 33 milliseconds after excitation is removed.



SPECTRAL-ENERGY EMISSION CHARACTERISTIC OF PHOSPHOR P4 SILICATE TYPE

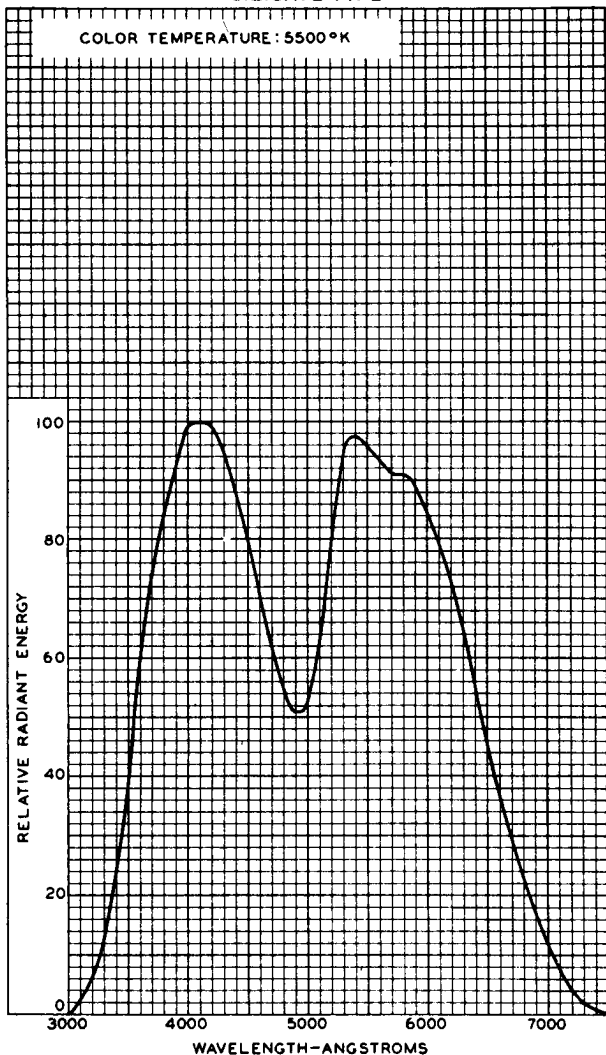

AUG. 2, 1949

TUBE DIVISION
RADIO CORPORATION OF AMERICA, HARRISON, NEW JERSEY

92CM-7335



PERSISTENCE CHARACTERISTIC OF PHOSPOR P4 SILICATE TYPE

The persistence of the phosphorescence is such that its brightness does not exceed 7 per cent of the peak value in 33 milliseconds after excitation is removed.



SPECTRAL-ENERGY EMISSION CHARACTERISTIC OF PHOSPHOR № 5

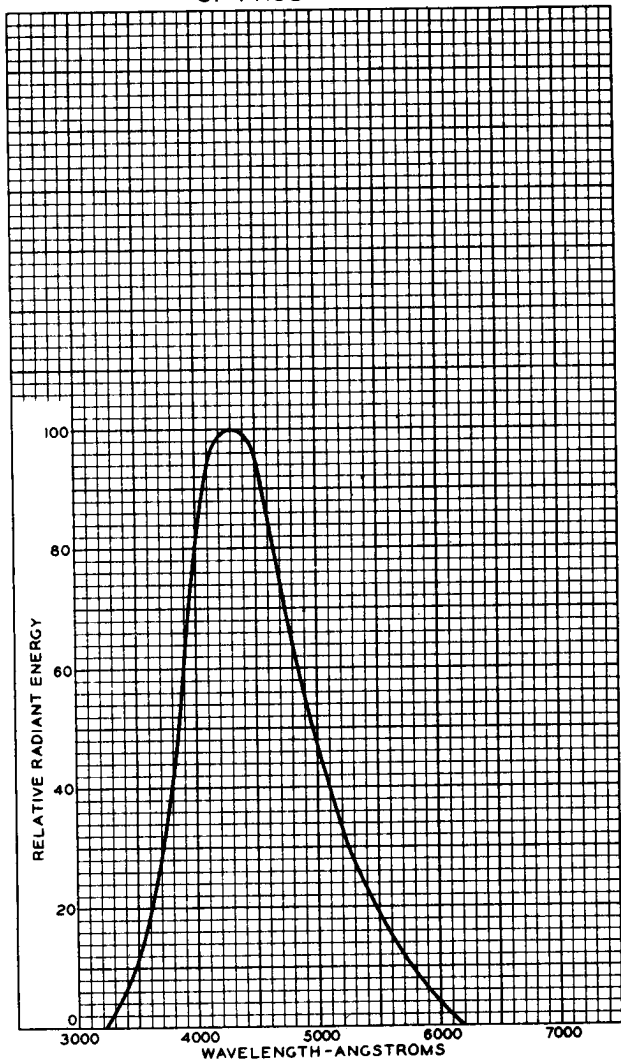

MAY 2, 1949

TUBE DEPARTMENT
RADIO CORPORATION OF AMERICA, HARRISON, NEW JERSEY

92CM-5559R2



PERSISTENCE CHARACTERISTIC OF PHOSPHOR № 5

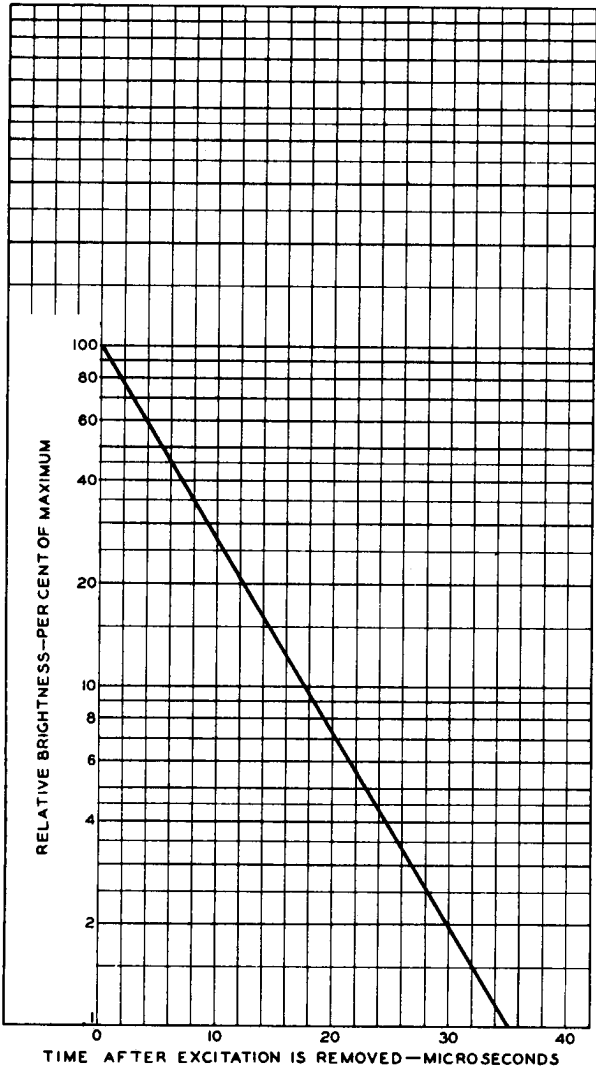

MAY 3, 1949

TUBE DEPARTMENT
RADIO CORPORATION OF AMERICA, HARRISON, NEW JERSEY

92CM-7266



SPECTRAL-ENERGY EMISSION CHARACTERISTIC OF PHOSPHOR P7

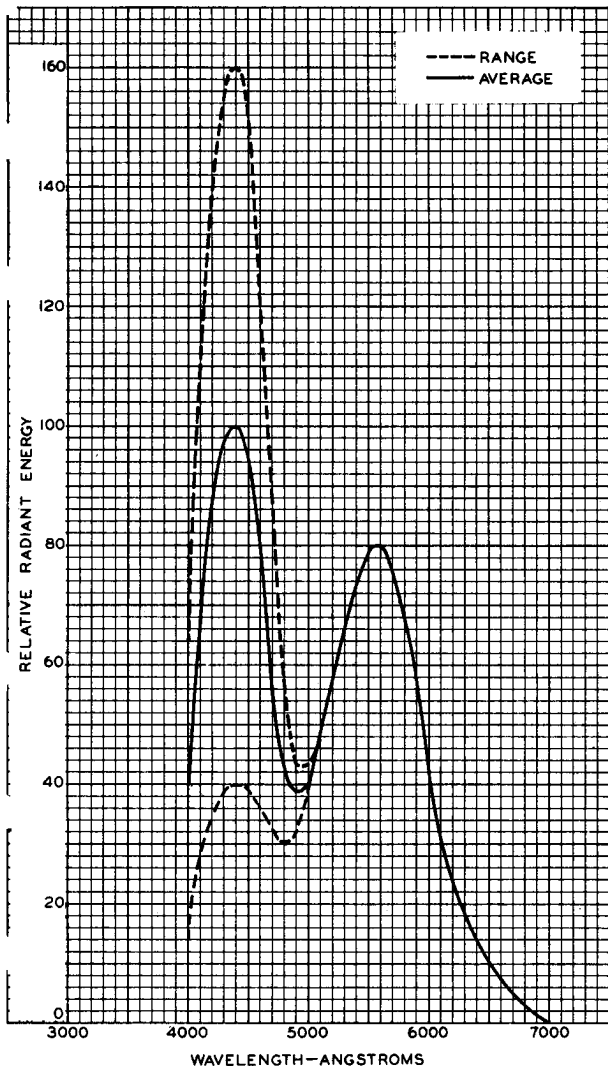



PERSISTENCE CHARACTERISTIC OF PHOSPHOR P7

FINAL HIGH-VOLTAGE-
ELECTRODE VOLTS: 4000-9000
SCREEN MICROAMP: 150
SCANNING AREA (CM): 7 x 7
SCANNING PERIOD (SEC): $\frac{1}{60}$
NUMBER OF LINES: 260 APPROX.
EXCITATION: SINGLE PULSE OF
0.24-MILLISECOND DURATION

Subdivisions are 2, 4, 6, 8

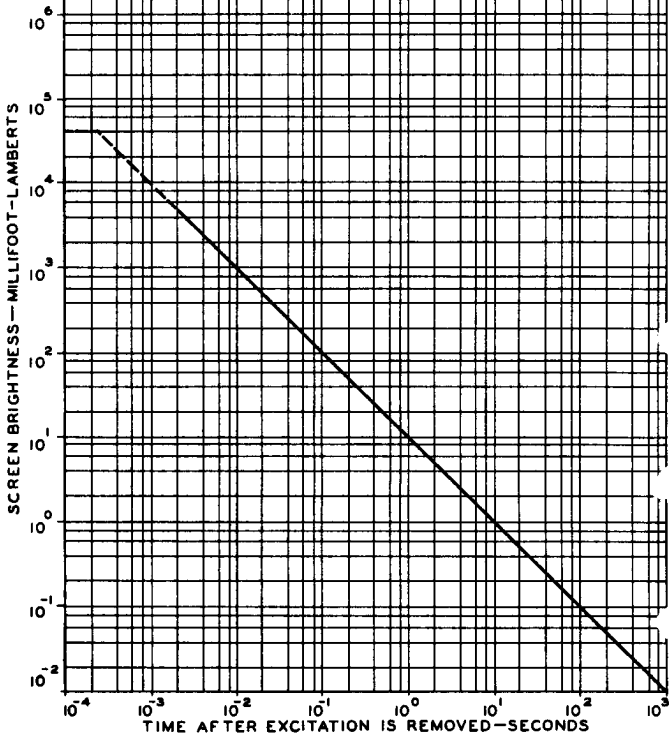

TUBE DIVISION

RADIO CORPORATION OF AMERICA, HARRISON, NEW JERSEY

92CM-7015R4



BUILDUP CHARACTERISTICS OF PHOSPHOR P7

FINAL HIGH-VOLTAGE-ELECTRODE VOLTS: 4000-9000
SCANNING AREA (CM): 7x7
NUMBER OF LINES: 260 APPROX.
EXCITATION: PULSE OF $\frac{1}{60}$ -SECOND DURATION
SUPPLIED TO GRID NO1 OF CATHODE-
RAY TUBE AT 1-SECOND INTERVALS
FOR EACH OF THE LOC1 UNDER
THE INDICATED CONDITIONS.
BRIGHTNESS: MEASURED JUST BEFORE EACH
EXCITATION PULSE.

LOCUS	SCREEN MICROAMP
A	150
B	75
C	37

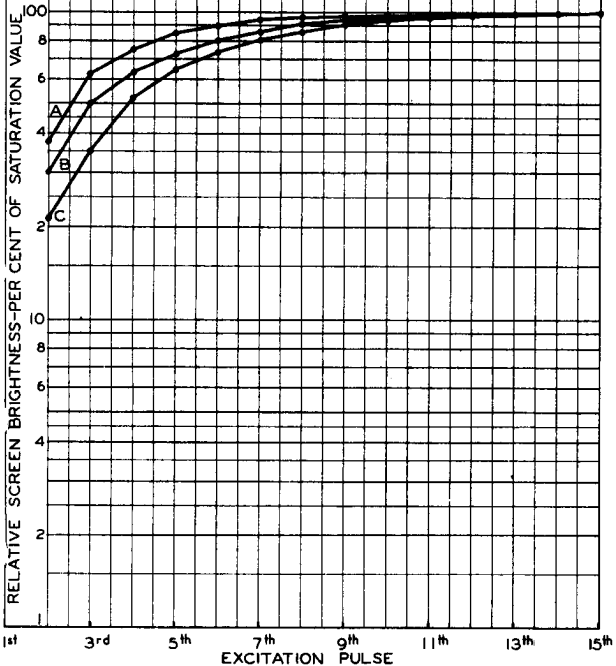



BUILDUP CHARACTERISTICS OF PHOSPHOR P7

SCANNING AREA (CM): 7x7

NUMBER OF LINES: 260 APPROX.

EXCITATION: PULSE OF $\frac{1}{60}$ -SECOND DURATION SUPPLIED
TO GRID N°1 OF CATHODE - RAY TUBE AT
1-SECOND INTERVALS FOR EACH OF THE
LOCI UNDER THE INDICATED CONDITIONS.

BRIGHTNESS: MEASURED JUST BEFORE EACH EXCITATION
PULSE.

LOCUS	FINAL HIGH-VOLTAGE- ELECTRODE VOLTS	SCREEN MICROAMP
A	4000	150
B	4000	75
C	2500	75
D	2500	37
E	1500	37

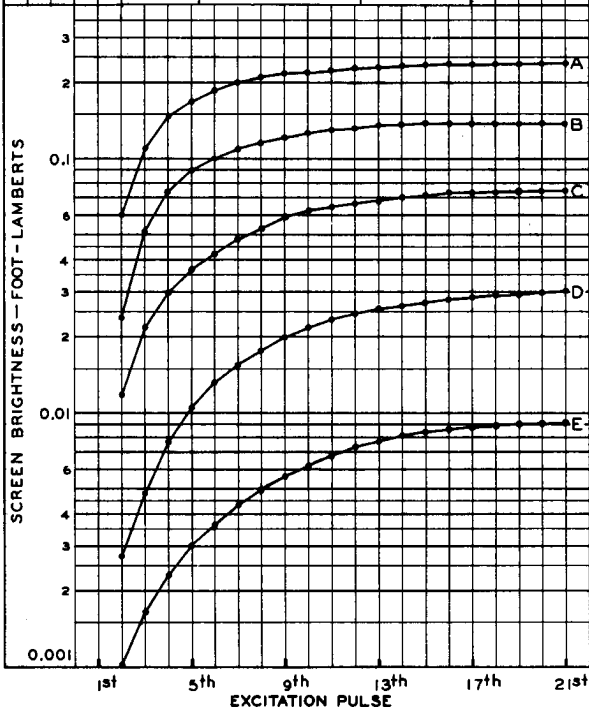



PERSISTENCE CHARACTERISTICS OF PHOSPHOR P7

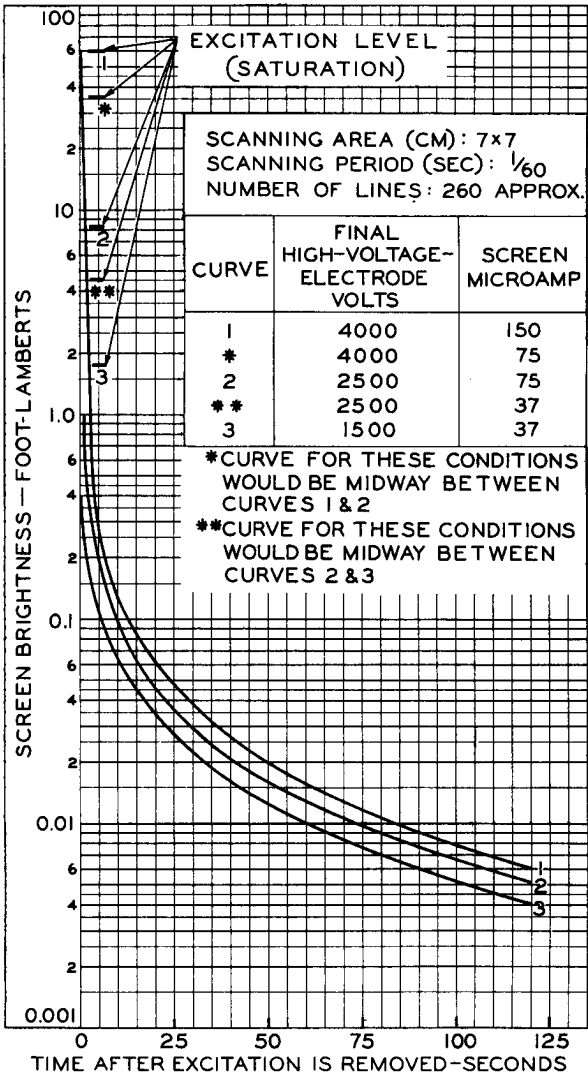

TUBE DIVISION

92CL-6804R5

RADIO CORPORATION OF AMERICA, HARRISON, NEW JERSEY



SPECTRAL-ENERGY EMISSION CHARACTERISTIC OF PHOSPHOR No 11

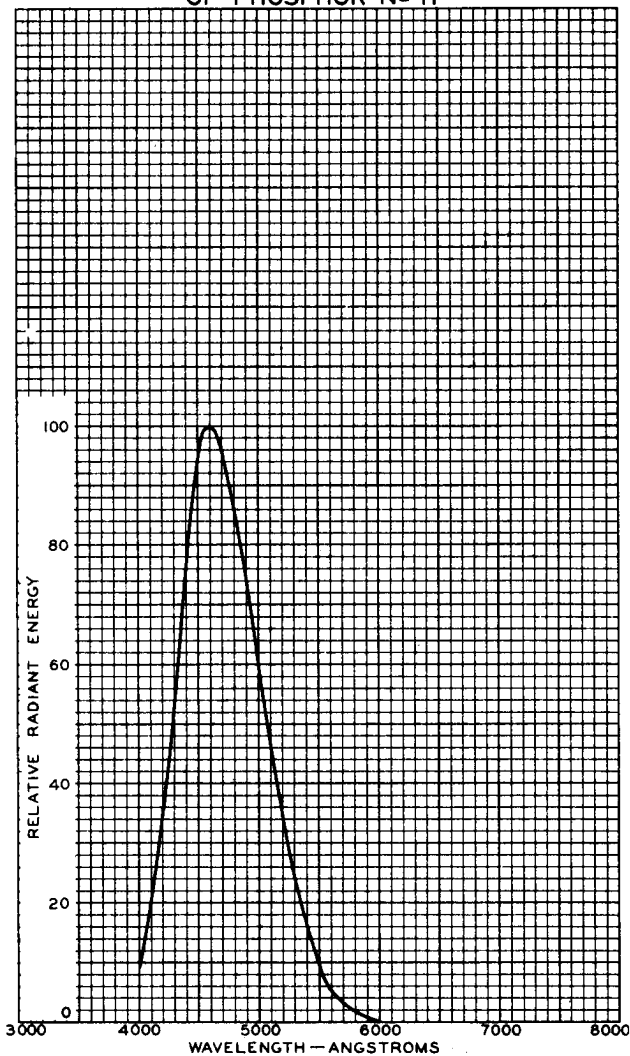

APRIL 9, 1946

TUBE DEPARTMENT
RADIO CORPORATION OF AMERICA, HARRISON, NEW JERSEY

92CM-6749



PERSISTENCE CHARACTERISTICS OF PHOSPHOR No 11

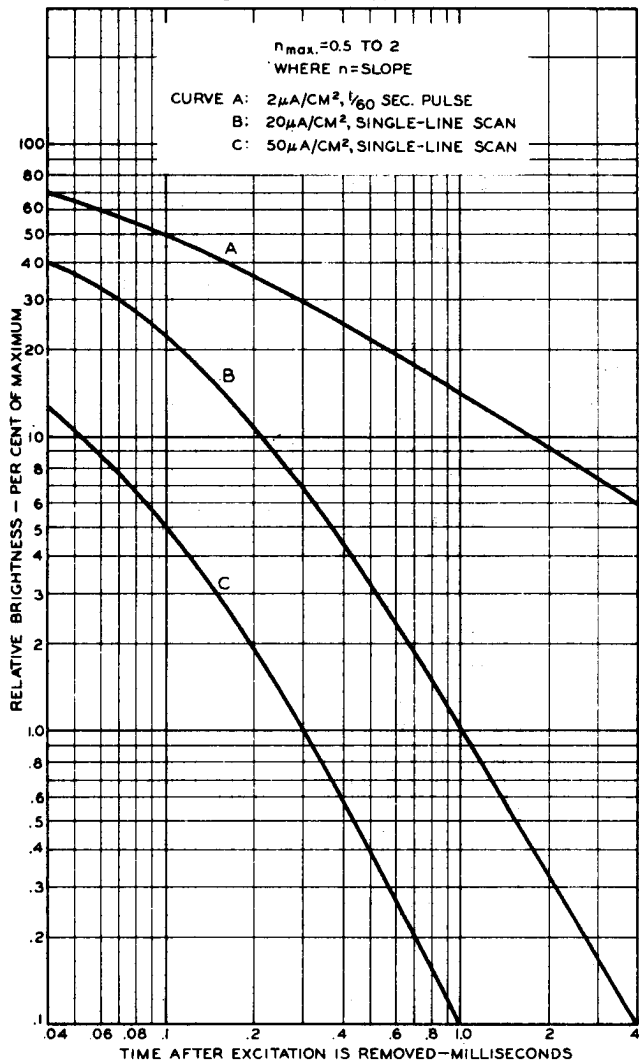

JULY 7, 1950

TUBE DEPARTMENT
RADIO CORPORATION OF AMERICA, HARRISON, NEW JERSEY

92CM-6806R2



SPECTRAL-ENERGY EMISSION CHARACTERISTIC OF PHOSPHOR P12

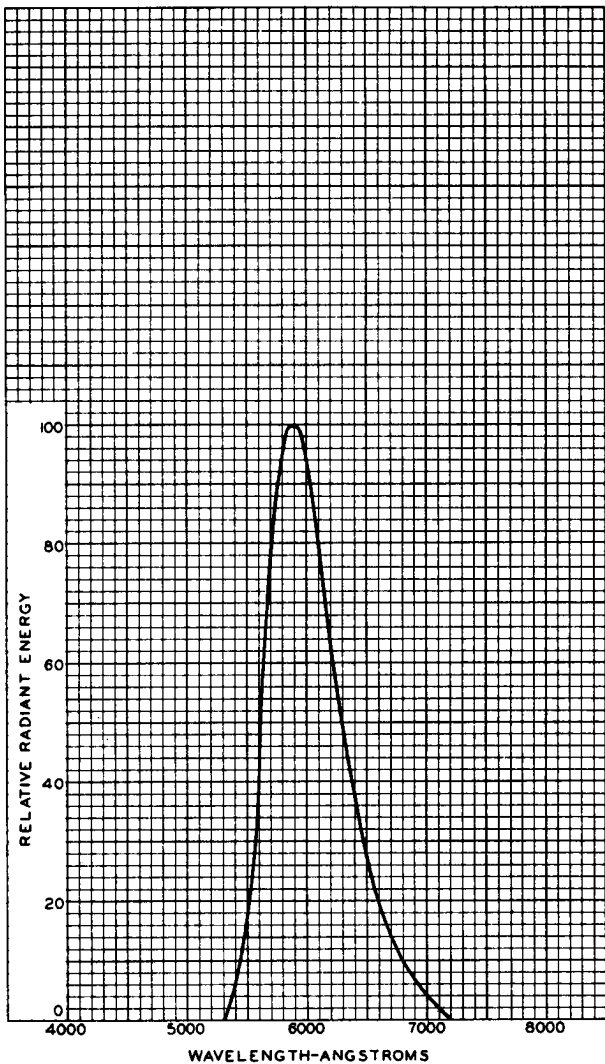

JULY 18, 1949

TUBE DEPARTMENT
RADIO CORPORATION OF AMERICA, HARRISON, NEW JERSEY

92CM-7317



PERSISTENCE CHARACTERISTIC OF PHOSPHOR P12

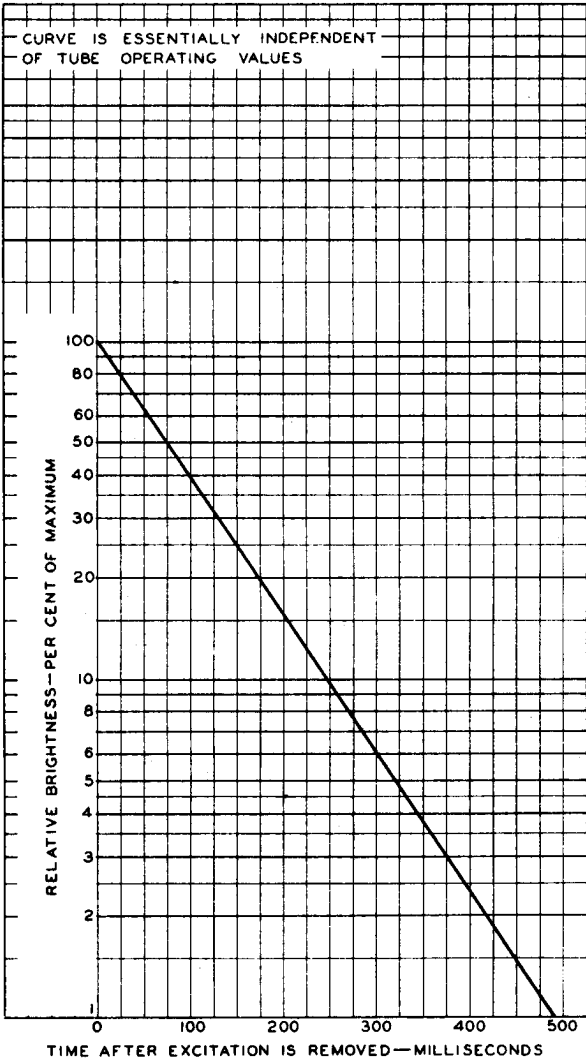



SPECTRAL-ENERGY EMISSION CHARACTERISTIC OF PHOSPHOR P14

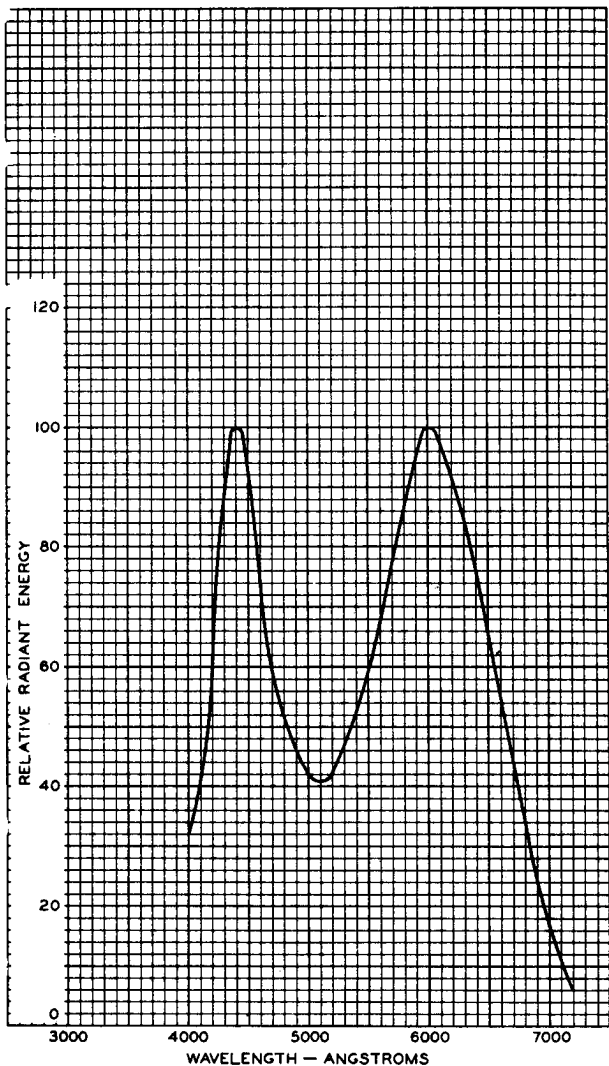

AUG. 1, 1951

TUBE DEPARTMENT
RADIO CORPORATION OF AMERICA, HARRISON, NEW JERSEY

92CM-7675



PERSISTENCE CHARACTERISTIC OF PHOSPHOR P14

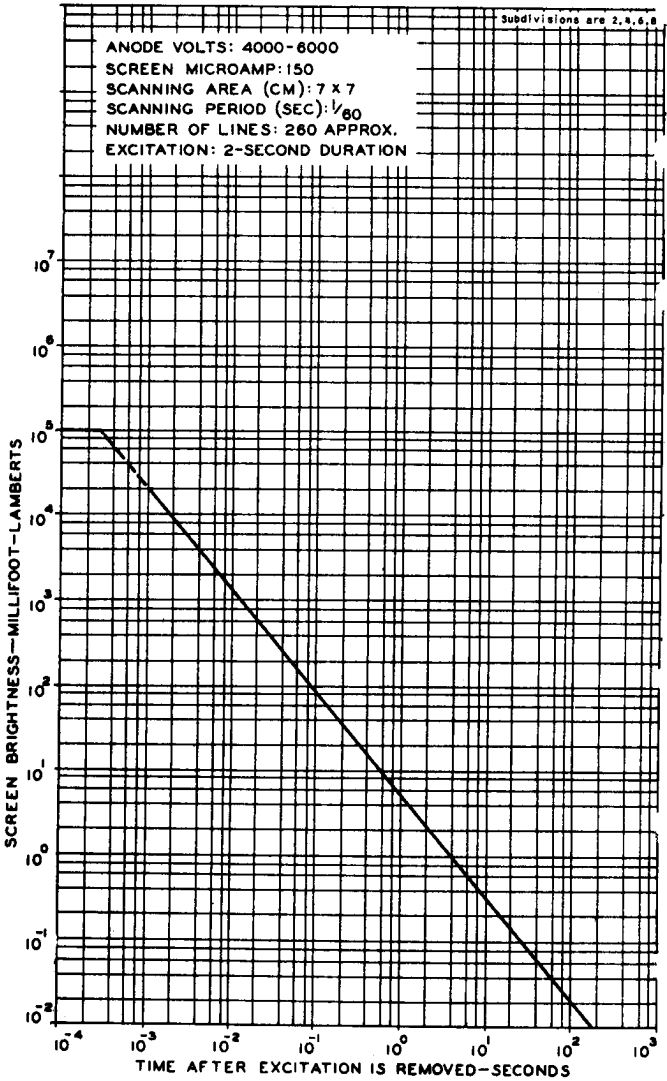

JAN. 26, 1951

TUBE DEPARTMENT

92CM-7326RI

RADIO CORPORATION OF AMERICA, HARRISON, NEW JERSEY



SPECTRAL-ENERGY EMISSION CHARACTERISTIC OF PHOSPHOR P15

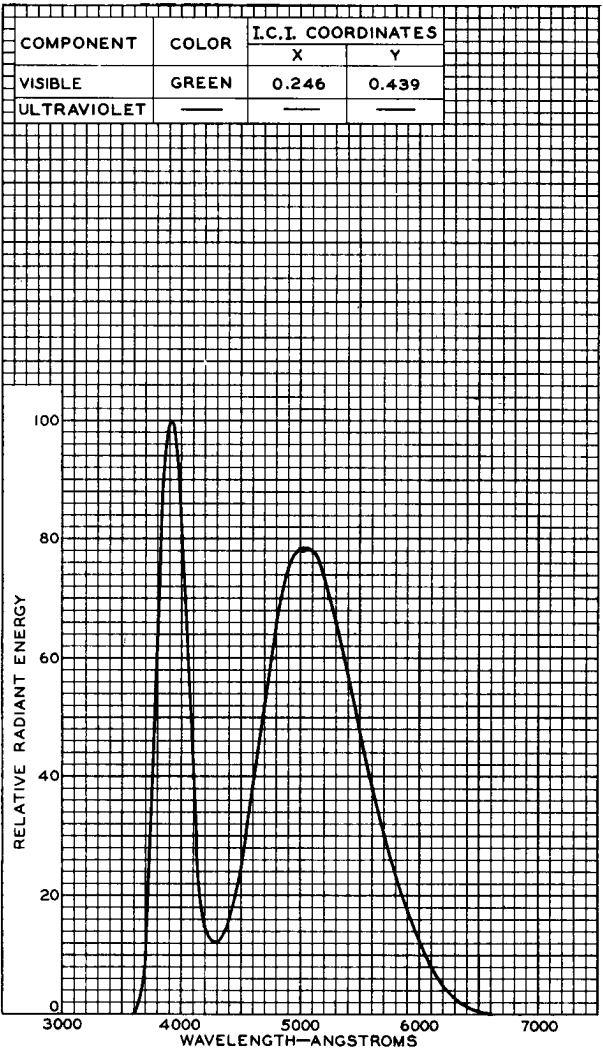



PERSISTENCE CHARACTERISTIC OF PHOSPHOR P15

COMPONENTS	EACH ESSENTIALLY INDEPENDENT OF TUBE OPERATING VALUES.
VISIBLE	SHOWN BY CURVE.
ULTRAVIOLET	DECAYS TO APPROXIMATELY 10% OF MAXIMUM IN NOT MORE THAN 0.05 MICROSECOND.

SPOT: SHARPLY FOCUSED.

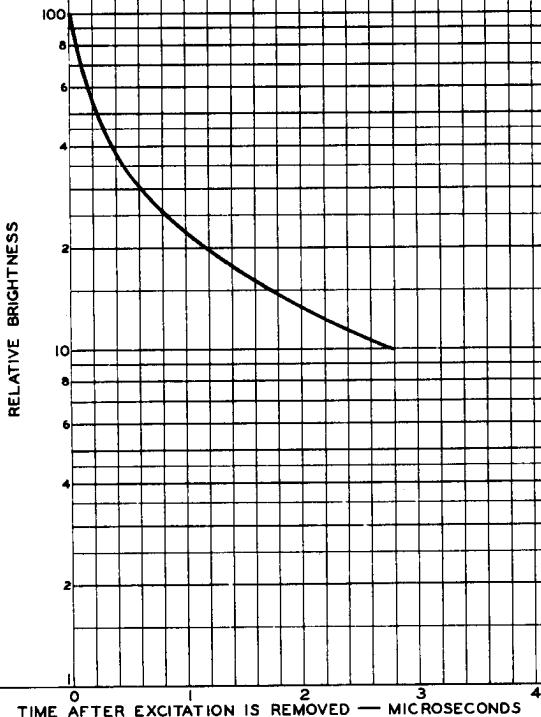



SPECTRAL-ENERGY EMISSION CHARACTERISTIC OF PHOSPHOR P16

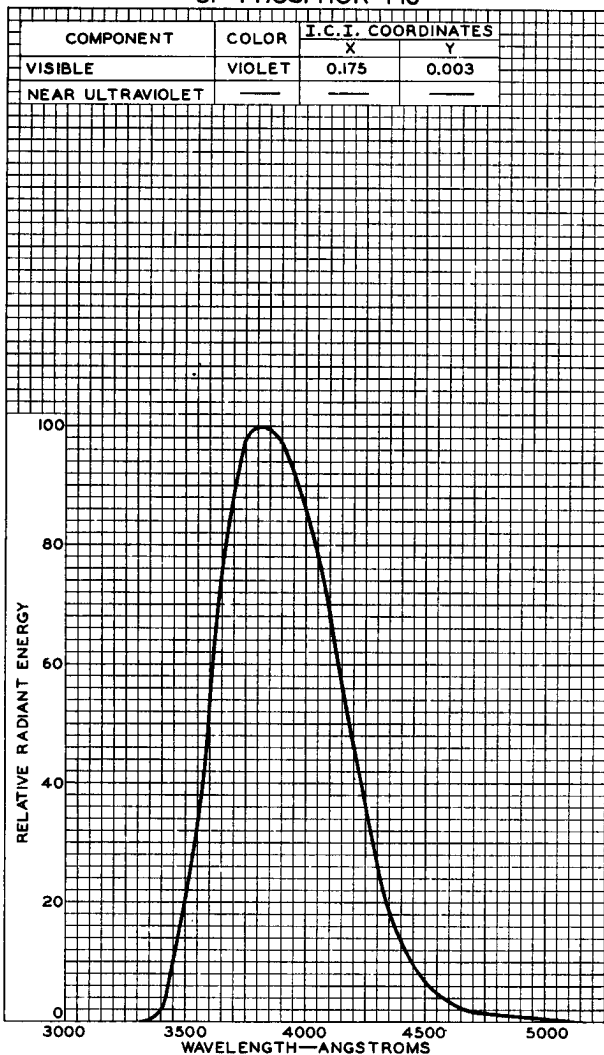



PERSISTENCE CHARACTERISTIC OF PHOSPHOR P16

CURVE IS ESSENTIALLY INDEPENDENT OF
TUBE OPERATING VALUES.
SPOT: SHARPLY FOCUSED.

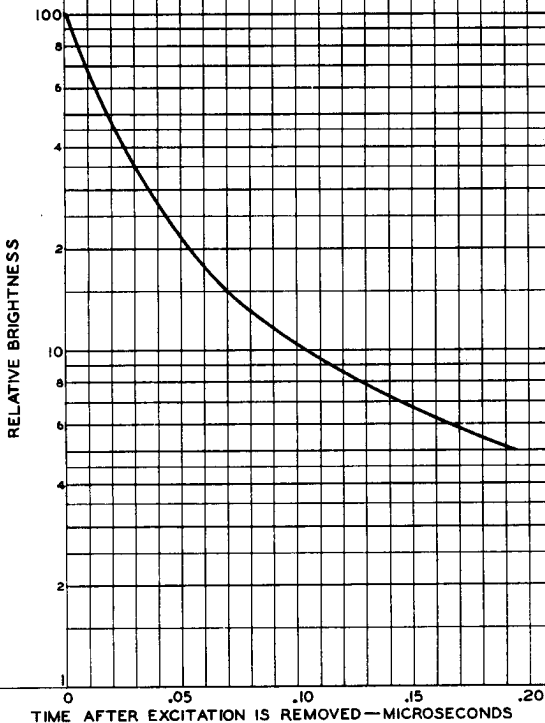

Spectral-Energy Emission Characteristic

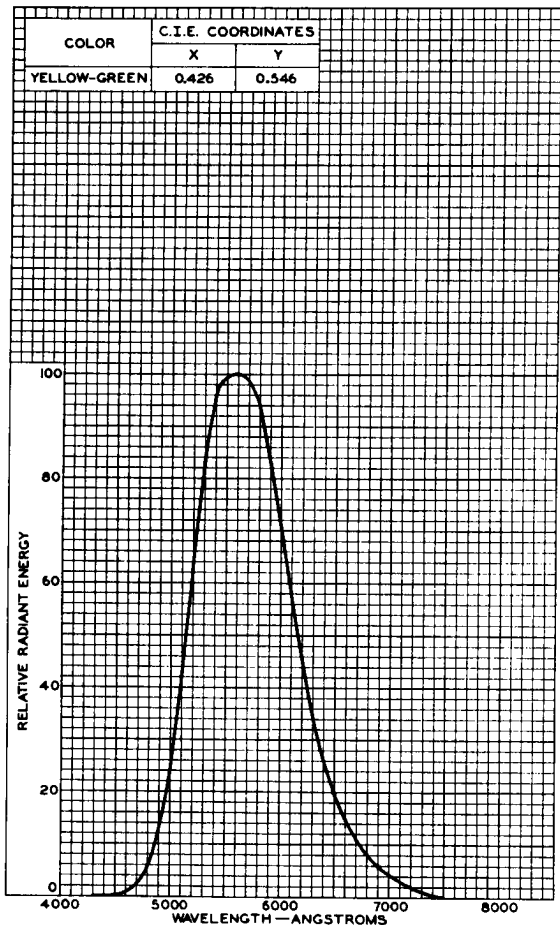

92CM-7647R2



RADIO CORPORATION OF AMERICA
Electronic Components and Devices
Harrison, N. J.

GROUP PHOS-
PHOR P20
4-66

Persistence Characteristic

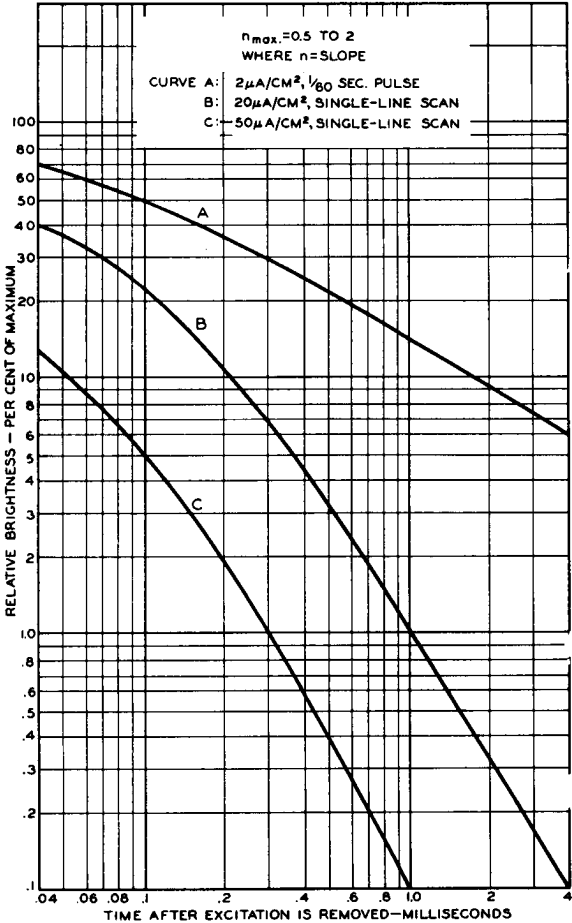

92CM-6806R.



Group Phosphor P22

SPECTRAL-ENERGY EMISSION CHARACTERISTIC

SIMULTANEOUS EXCITATION OF BLUE PHOSPHOR, GREEN PHOSPHOR, AND RED PHOSPHOR TO PRODUCE 8500° K
+27 M.P.C.D. WHITE ($X=0.287, Y=0.316$).

COMPONENT COLOR		CIE COORDINATES	
GENERAL DESCRIPTION	JEDEC DESIGNATION*	X	Y
BLUE	PURPLISH-BLUE	0.146	0.052
GREEN	YELLOWISH-GREEN	0.218	0.712
RED	REDDISH-ORANGE	0.674	0.326

*JEDEC COLOR CLASSIFICATION CORRESPONDING TO CIE COORDINATE VALUES.

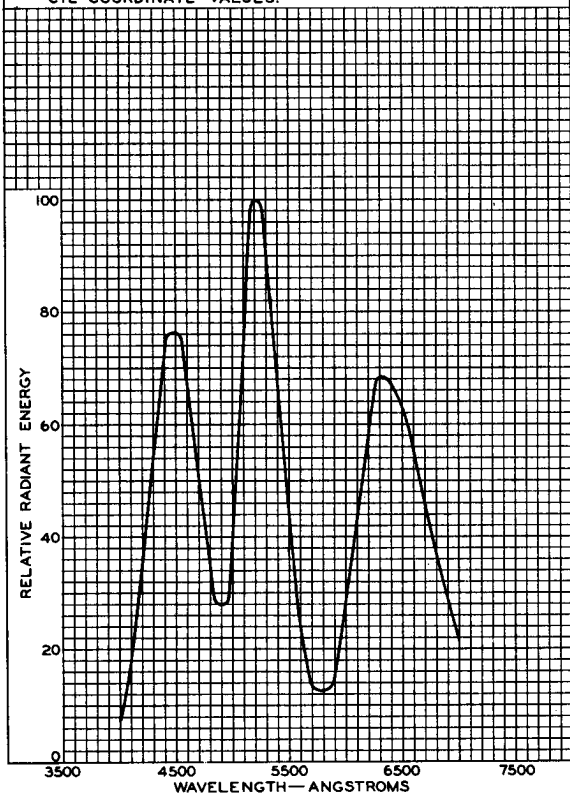

92CM-7969R4



RADIO CORPORATION OF AMERICA
Electron Tube Division
Harrison, N. J.

GROUP PHOS-
PHOR P22
10-60

Group Phosphor P22

PERSISTENCE CHARACTERISTIC

The persistence of the group phosphorescence is such that its brightness does not exceed 7 per cent of the peak value in 33 milliseconds after excitation is removed.



Group Phosphor P22

New Rare-Earth (Red), Sulfide (Blue & Green) Type^a

Spectral-Energy Emission Characteristic

^a The relative intensities of the narrow-emission bands of the red phosphor are dependent on the resolution of the measuring device.

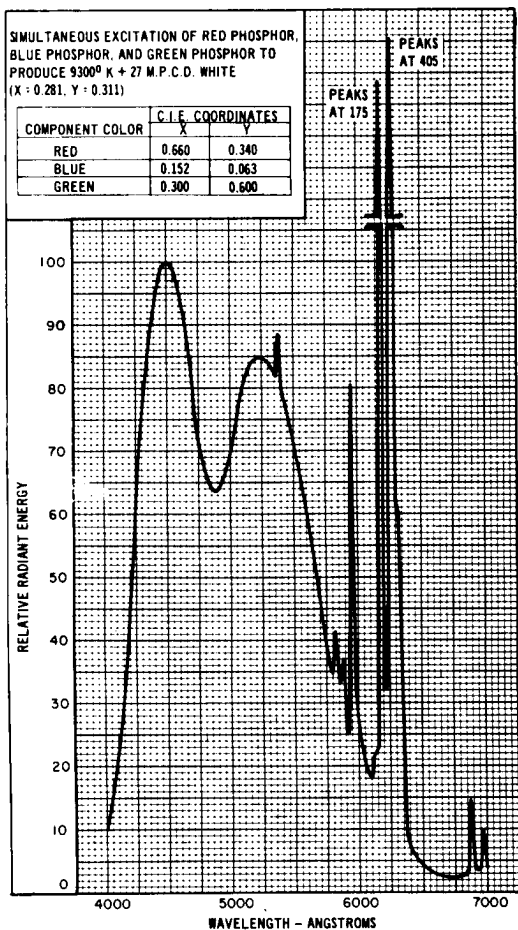

92LM-1952



RADIO CORPORATION OF AMERICA
Electronic Components and Devices

Harrison, N. J.

GROUP PHOS-
PHOR P22
4-67

Group Phosphor P22

New Rare-Earth (Red), Sulfide (Blue & Green) Type

PERSISTENCE CHARACTERISTIC

The persistence of the group phosphorescence is *medium short*. Persistence of the component phosphors is such that after excitation is removed, brightness decays to a level not exceeding 10 per cent of the initial value in:

22 microseconds (Approx.)	Blue phosphor
60 microseconds (Approx.)	Green phosphor
1 millisecond (Approx.)	Red phosphor





SPECTRAL-ENERGY EMISSION CHARACTERISTIC OF GROUP PHOSPHOR P22

EQUAL EXCITATION OF EACH PHOSPHOR

PHOSPHOR	RANGE OF MAX. VALUE ANGSTROMS
BLUE EMITTING	4420 TO 4520
GREEN EMITTING	5230 TO 5270
RED EMITTING	6360 TO 6580

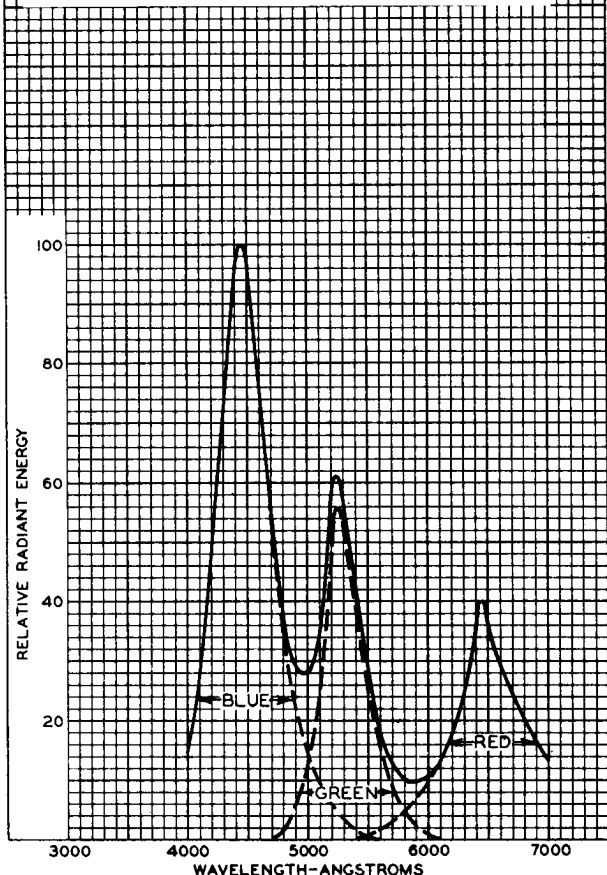



PERSISTENCE CHARACTERISTIC OF GROUP PHOSPHOR P22

The persistence of the group phosphorescence is such that its brightness does not exceed 7 per cent of the peak value in 33 milliseconds after excitation is removed.

Group Phosphor P22

Rare-Earth (Red), Sulfide (Blue & Green) Type^a

Spectral-Energy Emission Characteristic

^a The relative intensities of the narrow-emission bands of the red phosphor are dependent on the resolution of the measuring device.

SIMULTANEOUS EXCITATION OF RED PHOSPHOR, BLUE PHOSPHOR,
AND GREEN PHOSPHOR TO PRODUCE 9300° K + 27 M.P.C.D.
WHITE (X = 0.281, Y = 0.311).

COMPONENT COLOR	C.I.E. COORDINATES	
	X	Y
RED	0.676	0.324
BLUE	0.155	0.061
GREEN	0.290	0.590

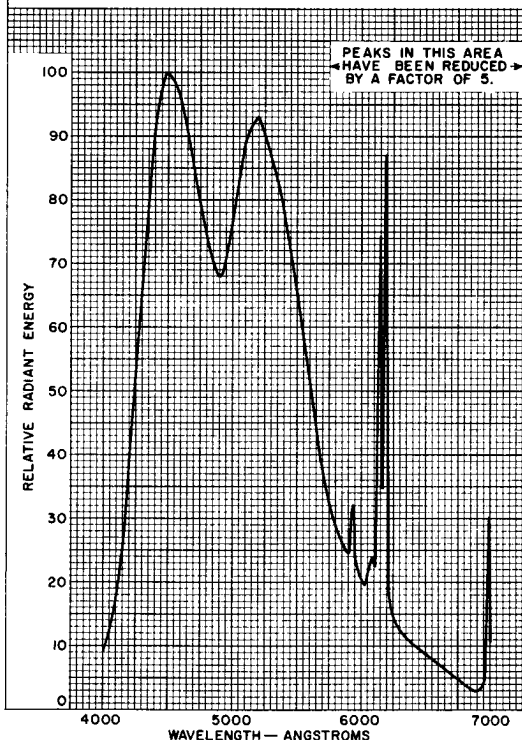

92CM-13088R1



RADIO CORPORATION OF AMERICA
Electronic Components and Devices
Harrison, N. J.

GROUP PHOS-
PHOR P22
9-65

Group Phosphor P22

Rare-Earth (Red), Sulfide (Blue & Green) Type

PERSISTENCE CHARACTERISTIC

The persistence of the group phosphorescence is *medium short*. Persistence of the component phosphors is such that after excitation is removed, brightness decays to a level not exceeding 10 per cent of the initial value in:

22 microseconds (Approx.)	Blue phosphor
60 microseconds (Approx.)	Green phosphor
1 millisecond (Approx.)	Red phosphor



Group Phosphor P22

All-Sulfide Type

SPECTRAL-ENERGY EMISSION CHARACTERISTIC

SIMULTANEOUS EXCITATION OF BLUE PHOSPHOR, GREEN PHOSPHOR, AND RED PHOSPHOR TO PRODUCE 9300° K +27 M.P.C.D. WHITE ($x=0.281, y=0.311$).

COMPONENT COLOR	C.I.E. COORDINATES	
	X	Y
BLUE	0.155	0.061
GREEN	0.265	0.585
RED	0.639	0.342

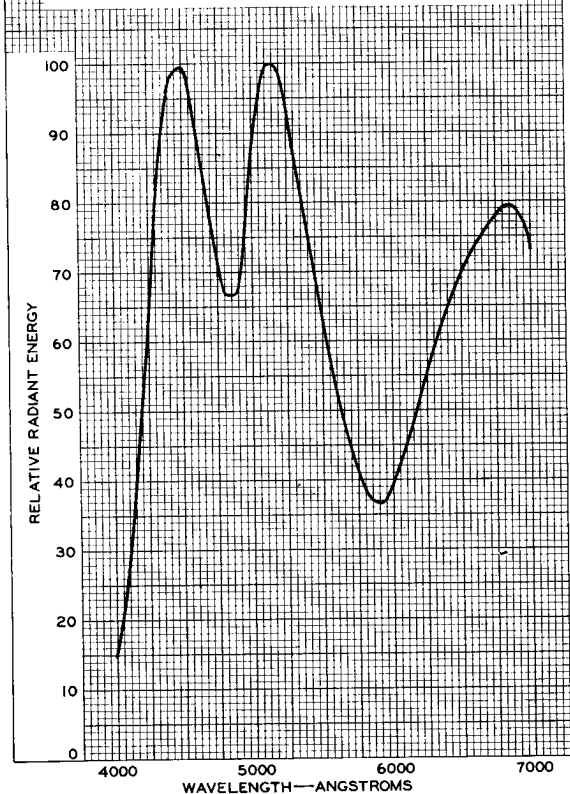

92CM-10857



RADIO CORPORATION OF AMERICA
Electron Tube Division
Harrison, N. J.

GROUP PHOS-
PHOR P22
5-61

Group Phosphor P22

All-Sulfide Type

PERSISTENCE CHARACTERISTIC

The persistence of the group phosphorescence is *medium short*. Persistence of the component phosphors is such that after excitation is removed, brightness decays to a level not exceeding 10 percent of the initial value in:

22 microseconds (Approx.).	Blue phosphor
60 microseconds (Approx.).	Green phosphor
60 microseconds (Approx.).	Red phosphor





SPECTRAL-ENERGY EMISSION CHARACTERISTIC OF PHOSPHOR P24

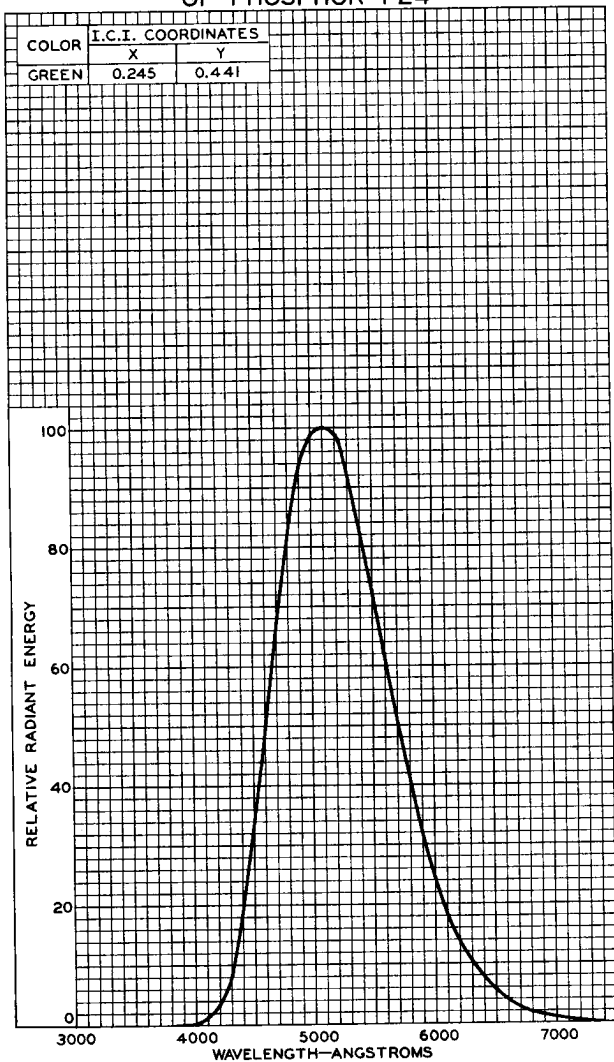



PERSISTENCE CHARACTERISTIC OF PHOSPHOR P24

CURVE IS ESSENTIALLY INDEPENDENT
OF TUBE OPERATING VALUES.

SPOT: SHARPLY FOCUSED.

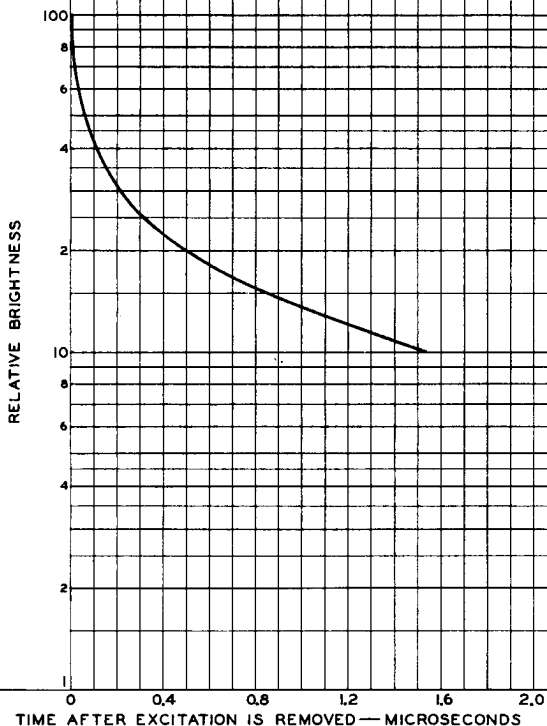

ELECTRON TUBE DIVISION

92CM-8205R2

RADIO CORPORATION OF AMERICA, HARRISON, NEW JERSEY

JEDEC PHOSPHOR P31

Spectral-Energy Emission Characteristic

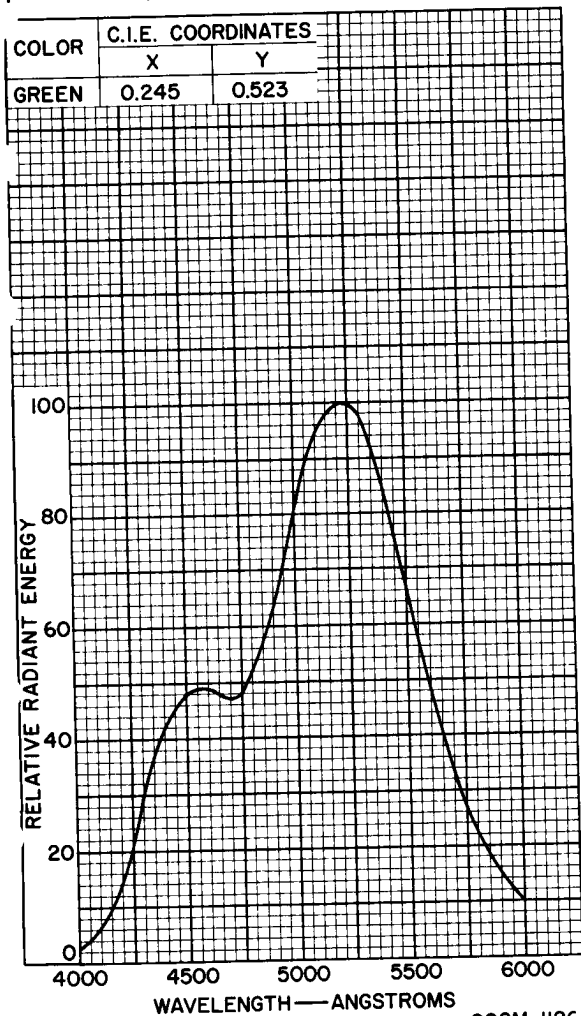

92CM-11261



Electronic
Components

JEDEC PHOSPHOR P31

6-72

JEDEC PHOSPHOR P31

Persistence Characteristic

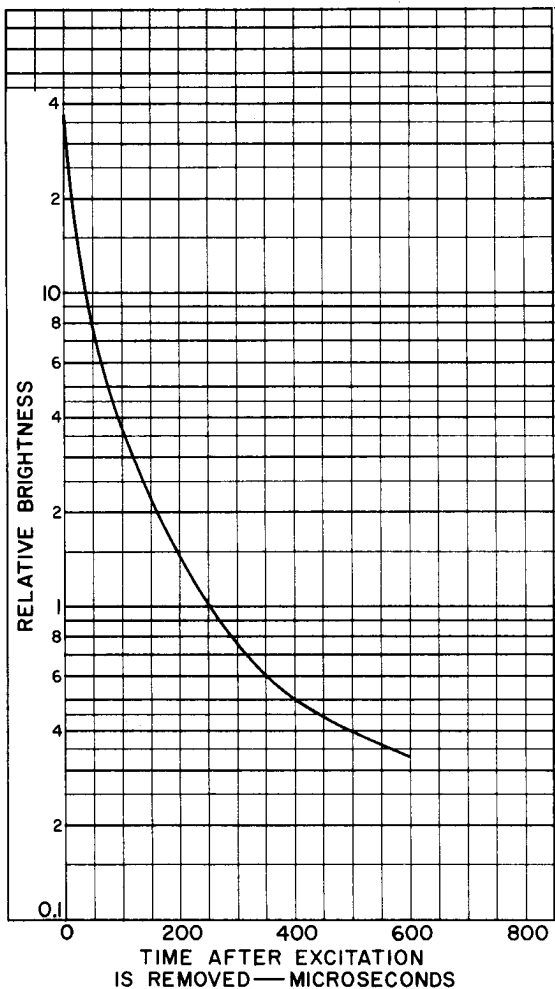

92CM-11277

Picture-Tube Dimensional Outlines

The *Dimensional Outlines* on the following pages provide the basic dimensions of RCA Picture Tubes. These Dimensional Outlines are classified by Bulb Designations in accordance with the designation system established by the American Standards Association. Tube neck length, tube overall length, base designation, and the configuration of the external conductive coating (when used) are not shown on these Dimensional Outlines. These items are covered on the data sheets for specific picture-tube types.

The terms used in the picture-tube data sheets to describe the *Type of External Conductive Coating* and the *Contact Area for Grounding* are defined below:

Type of External Conductive Coating

Regular Band. A band of external conductive coating of uniform height covering part of the bulb funnel. The band may entirely encompass the funnel except for an insulated area in the region of the anode (ultor) contact.

Modified Band. A coating configuration similar to a Regular Band except for special contouring of the upper and/or lower edges.

Special. A coating configuration not defined in the industry specification for the tube type.

Contact Area for Grounding

Near Reference Line. Refers to the position of the contact area usually employed for grounding a Regular or Modified Band of external conductive coating. A spring-finger contact mounted on the deflecting yoke or on the tube mounting assembly is normally employed for grounding the external conductive coating.

Special. Indicates that one or more contact areas for grounding the external conductive coating other than the area near the reference line are provided in the industry specification for the tube type.



Dimensional Outline Bulb J67-1/2 A

FOR PICTURE TUBES UTILIZING BULB J67-1/2 A

(For bulbs with and without integral protective window)

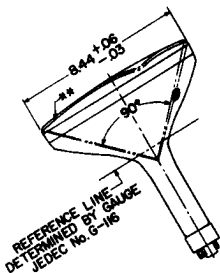
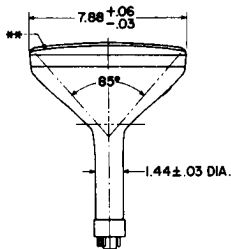
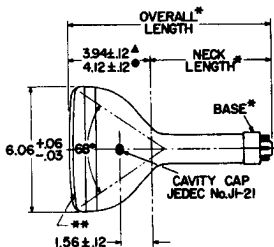
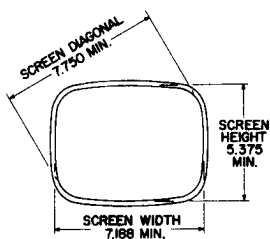

92CL-12472

DIMENSIONS IN INCHES

- * See data for specific tube type.
- ** Integral protective window is indicated.
- ▲ For bulb without protective window.
- For bulb with protective window.



Dimensional Outline Bulb J67-1/2 B

FOR PICTURE TUBES UTILIZING BULB J67-1/2 B

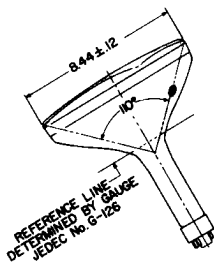
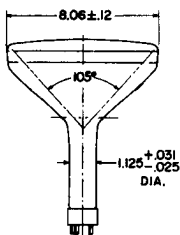
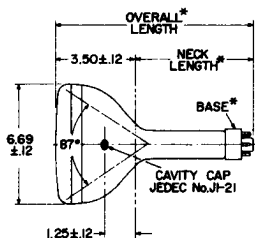
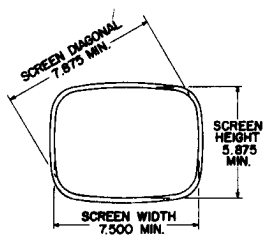

92CL-12854

DIMENSIONS IN INCHES

* See data for specific tube type.



RADIO CORPORATION OF AMERICA
Electronic Components and Devices
Harrison, N. J.

CRT
OUTLINES 1A
4-65

Dimensional Outline Bulb J109-1/2 A/C

FOR PICTURE TUBES UTILIZING BULB J109-1/2 A/C

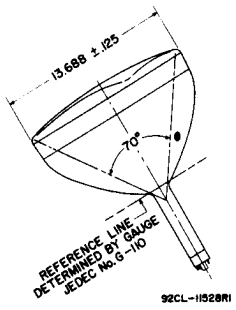
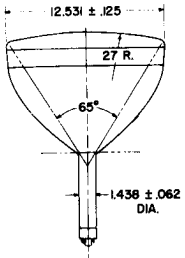
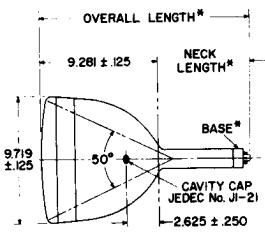
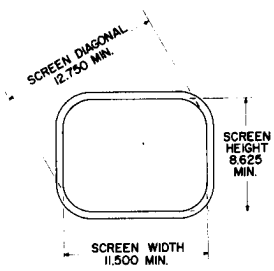

DIMENSIONS IN INCHES

* See data for specific tube type.



Dimensional Outline

Bulb J112 A/B

FOR PICTURE TUBES UTILIZING BULB J112 A/B

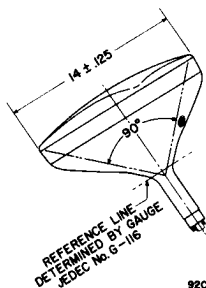
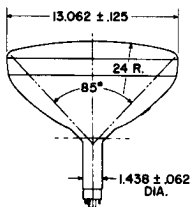
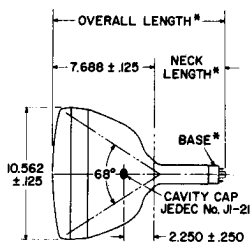
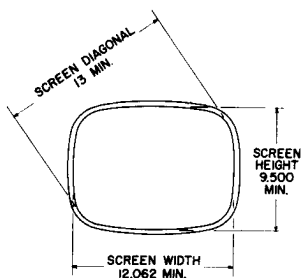

92CL-11506R1

DIMENSIONS IN INCHES

* See data for specific tube type.



RADIO CORPORATION OF AMERICA
Electronic Components and Devices
Harrison, N. J.

CRT
OUTLINES 2
4-65

Dimensional Outline

Bulb J125 A

FOR PICTURE TUBES UTILIZING BULB J125 A
AND PROTECTIVE WINDOW (FP125 A)

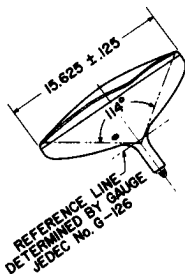
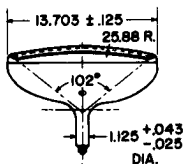
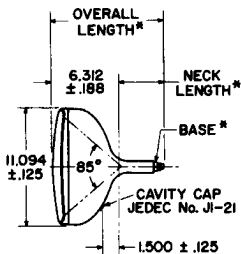
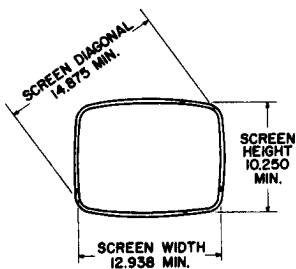

92CL-12264R1

DIMENSIONS IN INCHES

* See data for specific tube type.



FOR PICTURE TUBE UTILIZING BULB J125 B

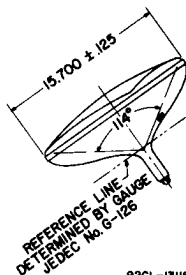
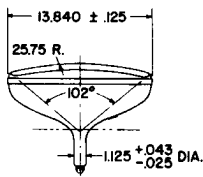
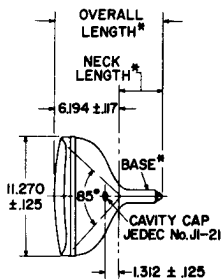
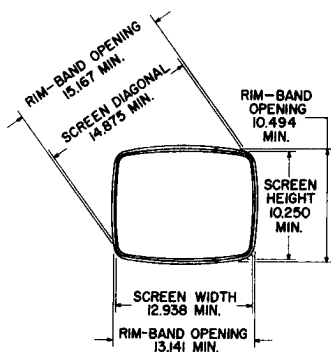

92CL-13118

DIMENSIONS IN INCHES

* See data for specific tube type.



Dimensional Outline

FOR PICTURE TUBES UTILIZING BULB J125 C2

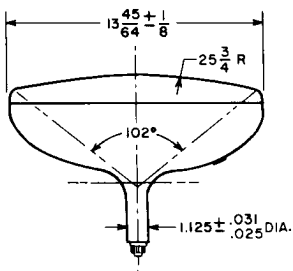
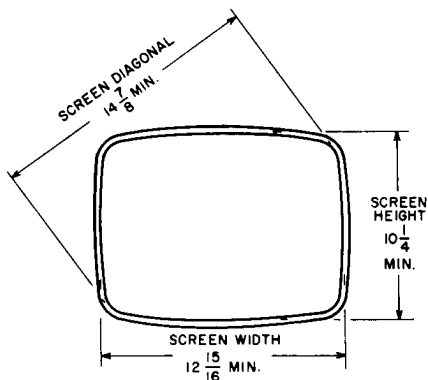

RADIO CORPORATION OF AMERICA
Electronic Components and Devices

Harrison, N. J.



Bulb J125 C2

BULB J125 C2

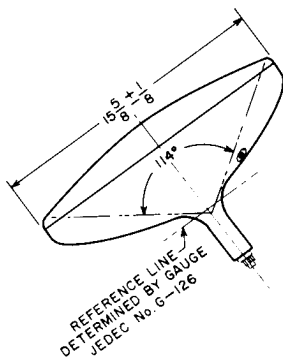
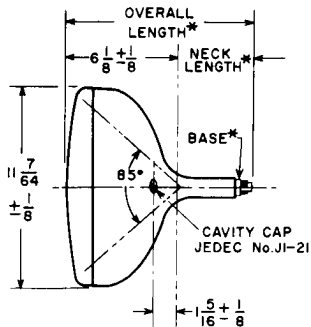

92CL-12037

DIMENSIONS IN INCHES

* See data for specific tube type.



RADIO CORPORATION OF AMERICA
Electronic Components and Devices
Harrison, N. J.

CRT
OUTLINES 4
10-65

Dimensional Outline Bulb J129 A/B

FOR PICTURE TUBES UTILIZING BULB J129 A/B

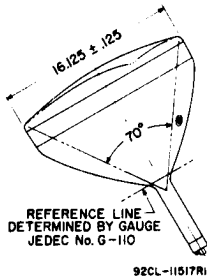
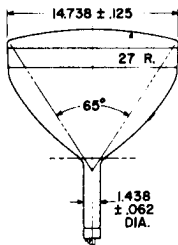
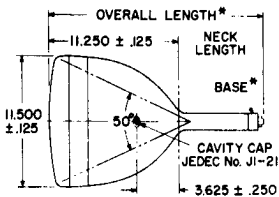
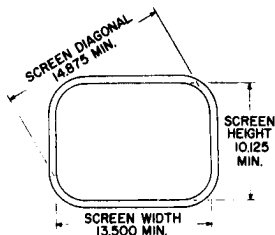

DIMENSIONS IN INCHES

* See data for specific tube type.



Dimensional Outline Bulb J132-1/2 A/B

FOR PICTURE TUBES UTILIZING BULB J132-1/2 A/B

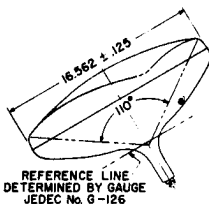
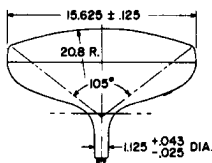
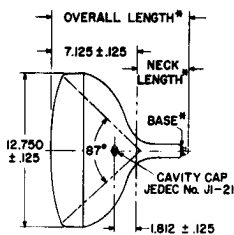
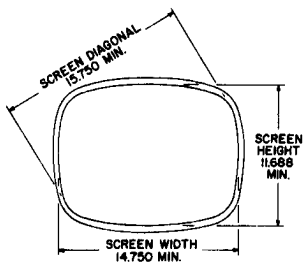

92CL-11589R1

DIMENSIONS IN INCHES

* See data for specific tube type.



RADIO CORPORATION OF AMERICA
Electronic Components and Devices

Harrison, N. J.

CRT
OUTLINES 5
10-65

Dimensional Outline

FOR PICTURE TUBES UTILIZING BULB J132-1/2 C/D

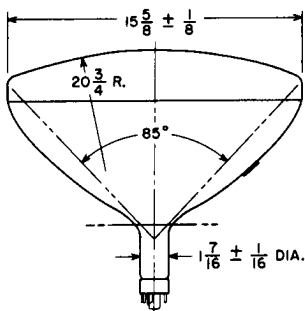
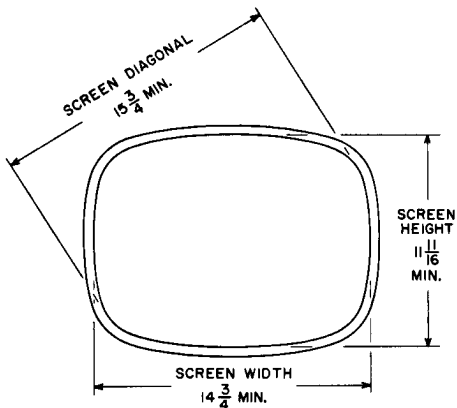

Bulb J132-1/2 C/D

BULB J132-1/2 C/D

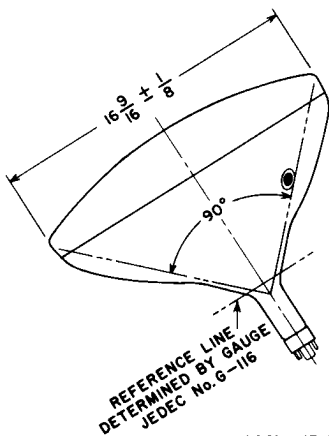
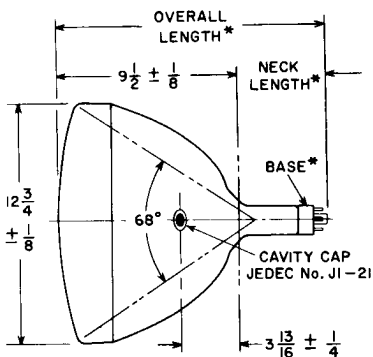

92CL-11514

ALL DIMENSIONS IN INCHES

* See data for specific tube type.



RADIO CORPORATION OF AMERICA
Electron Tube Division

Harrison, N. J.

CRT
OUTLINES 6
3-62

Dimensional Outline

FOR PICTURE TUBES UTILIZING

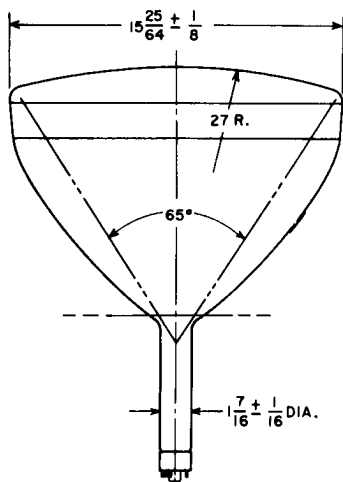
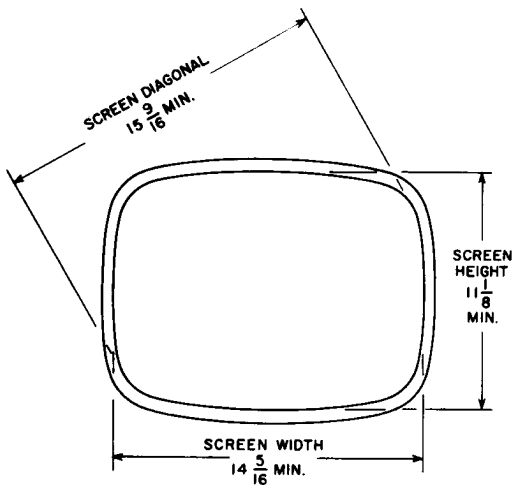

Bulb J133 B/D

BULB J133 B/D

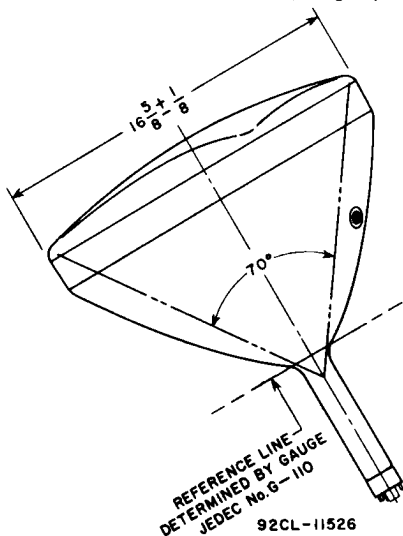
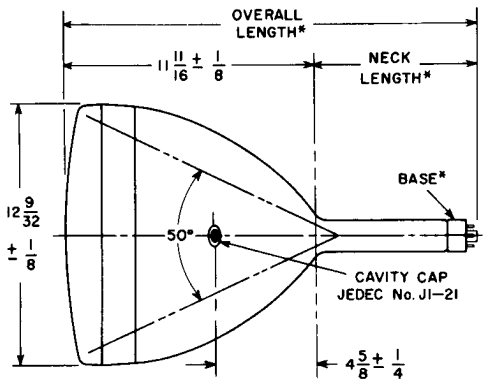

ALL DIMENSIONS IN INCHES

* See data for specific tube type.



RADIO CORPORATION OF AMERICA
Electron Tube Division
Harrison, N. J.

CRT
OUTLINES 7
3-62

Dimensional Outline

FOR PICTURE TUBES UTILIZING

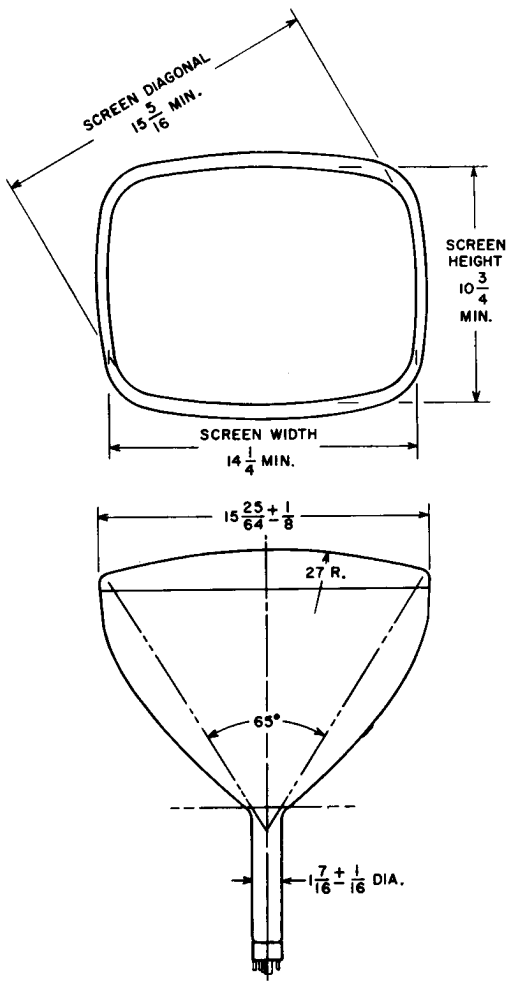

RADIO CORPORATION OF AMERICA
Electron Tube Division

Harrison, N. J.



Bulb J133 C/E

BULB J133 C/E

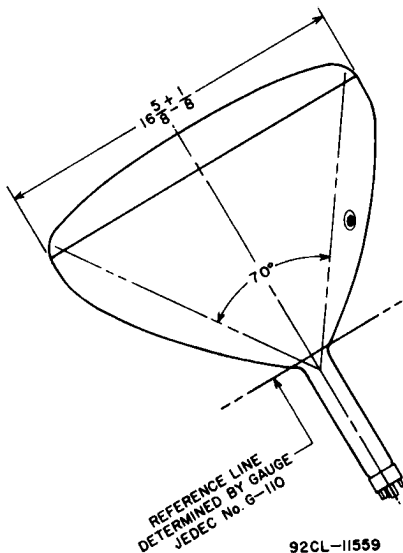
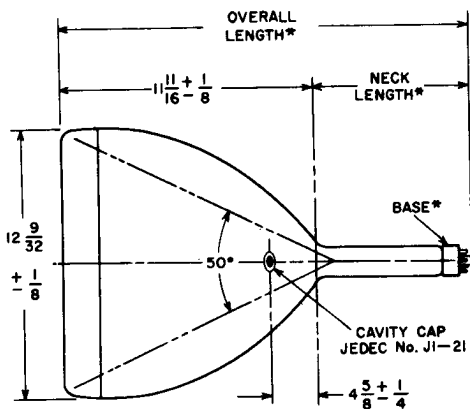

ALL DIMENSIONS IN INCHES

* See data for specific tube type.



RADIO CORPORATION OF AMERICA
Electron Tube Division
Harrison, N. J.

CRT
OUTLINES 8
3-62

Dimensional Outline

FOR PICTURE TUBES UTILIZING

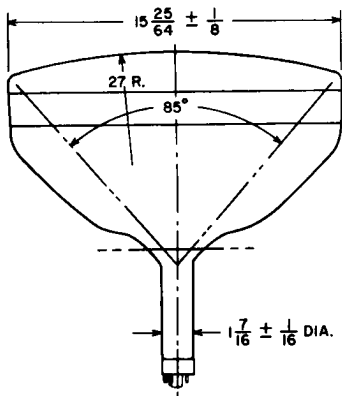
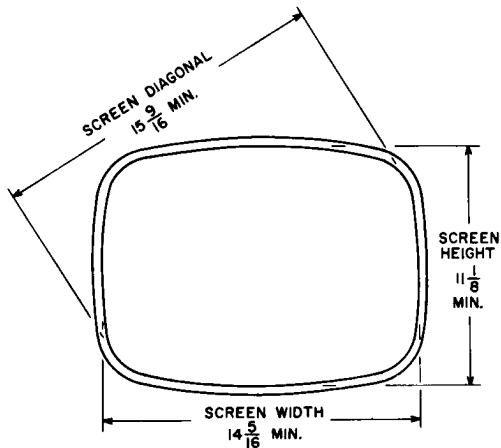

Bulb J133 F/G

BULB J133 F/G

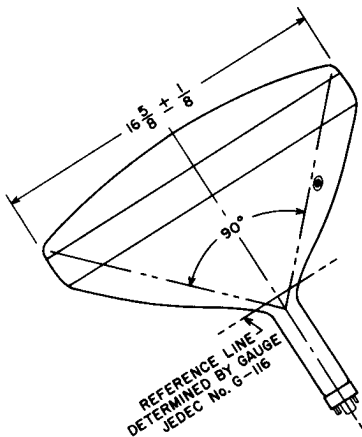
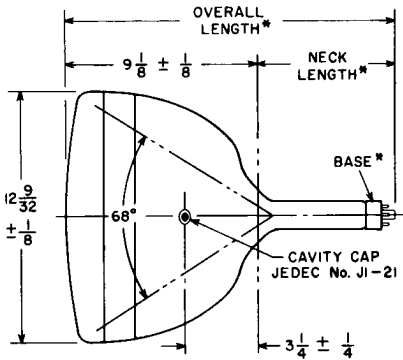

92CL-11557

DIMENSIONS IN INCHES

* See data for specific tube type.



RADIO CORPORATION OF AMERICA
Electronic Components and Devices
Harrison, N. J.

CRT
OUTLINES 9
10-65

FOR PICTURE TUBES UTILIZING BULB J149 A

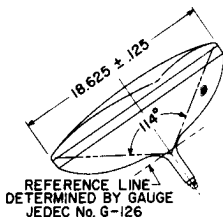
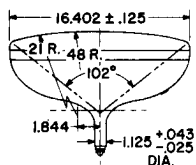
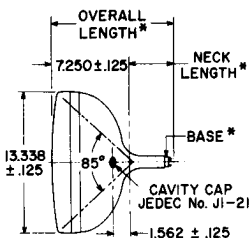
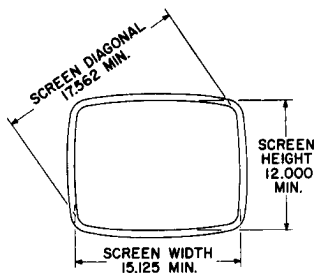

92CL-11510R1

DIMENSIONS IN INCHES

* See data for specific tube type.

FOR PICTURE TUBES UTILIZING BULB J149 B

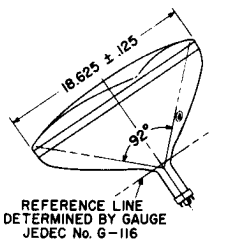
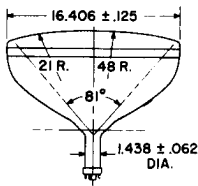
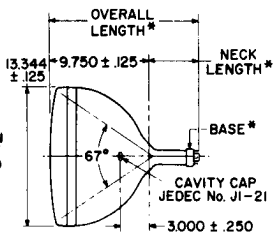
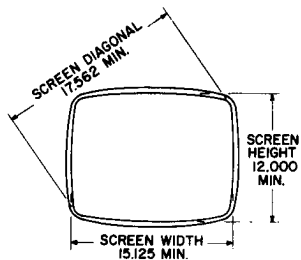

92CL-11604RI

DIMENSIONS IN INCHES

* See data for specific tube type.



Dimensional Outline

Bulb J149 C

FOR PICTURE TUBES UTILIZING BULB J149 C AND PROTECTIVE PANEL

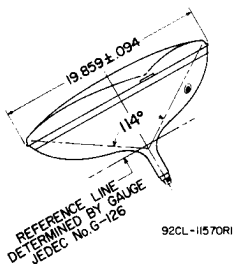
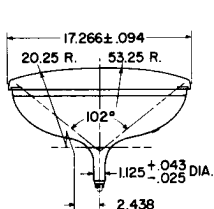
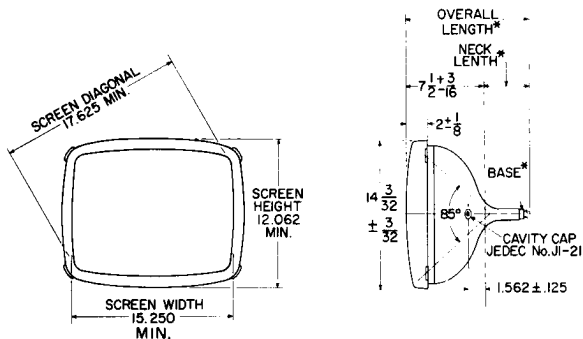

92CL-11570R1

DIMENSIONS IN INCHES

* See data for specific tube type.



FOR PICTURE TUBES UTILIZING BULB J149 F

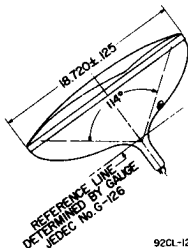
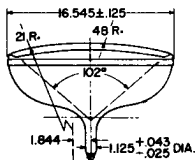
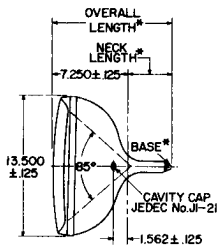
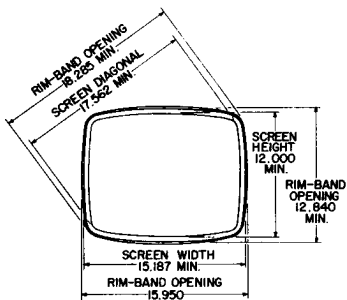

92CL-12356RI

DIMENSIONS IN INCHES

*See data for specific tube type.



Dimensional Outline

FOR PICTURE TUBES UTILIZING BULB J161 C/D

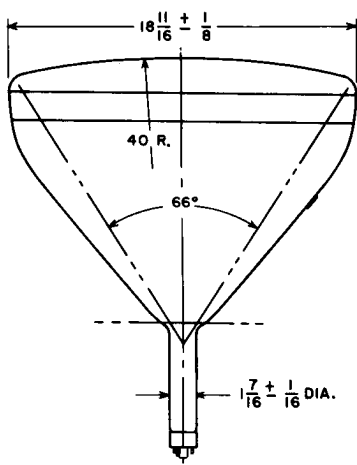
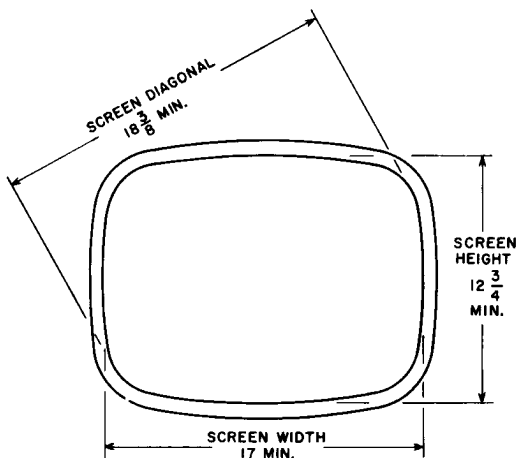

Bulb J161 C/D

BULB J161 C/D

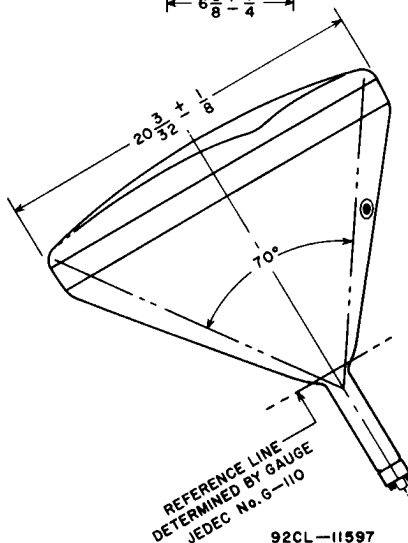
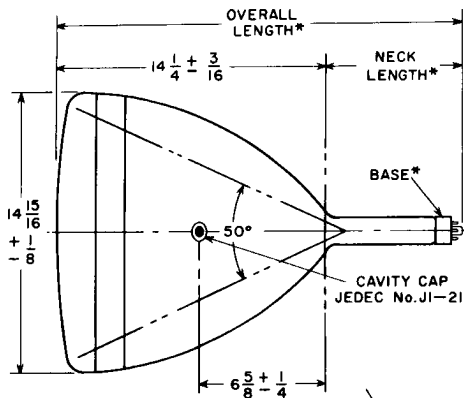

ALL DIMENSIONS IN INCHES

* See data for specific tube type.



RADIO CORPORATION OF AMERICA
Electron Tube Division
Harrison, N. J.

CRT
OUTLINES 13
3-62

Dimensional Outline

FOR PICTURE TUBES UTILIZING

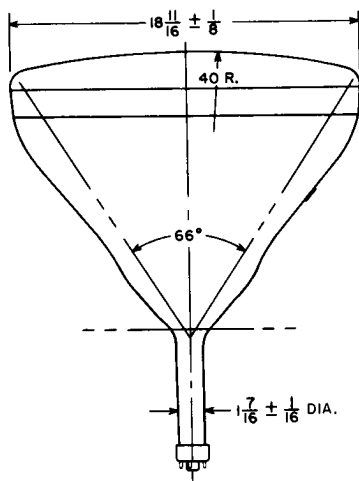
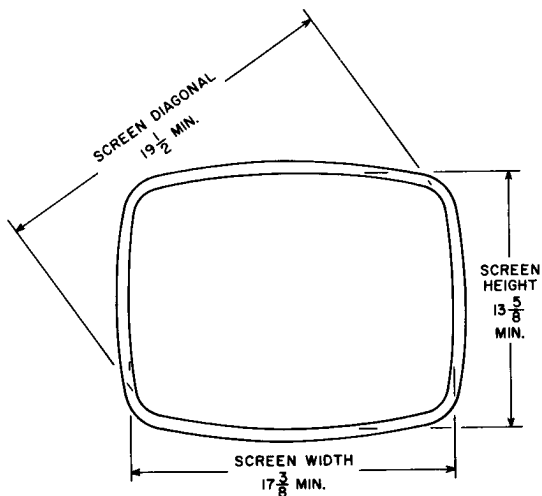

BULB J165 Z

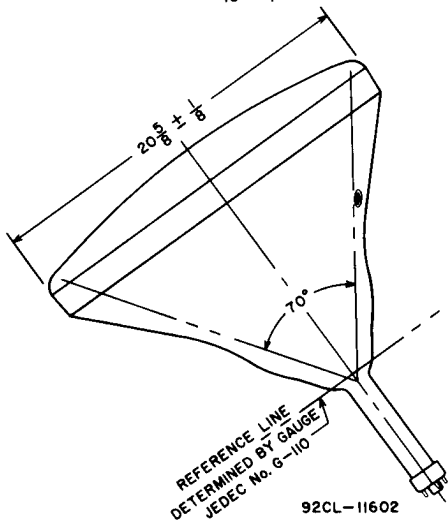
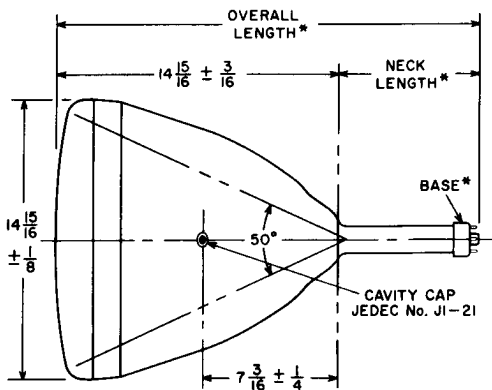

ALL DIMENSIONS IN INCHES

*See data for specific tube type.



RADIO CORPORATION OF AMERICA
Electron Tube Division
Harrison, N. J.

CRT
OUTLINES 14
3-62

Dimensional Outline

FOR PICTURE TUBES UTILIZING

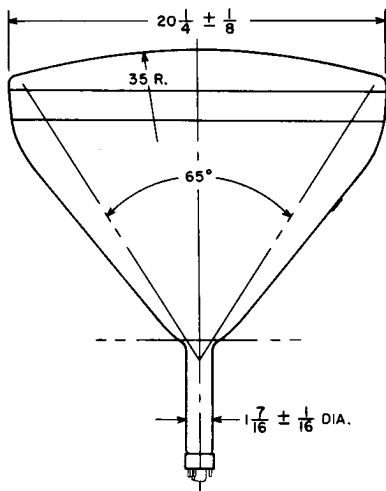
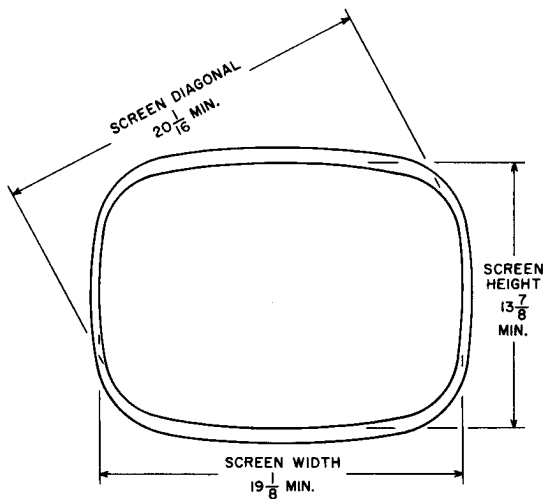

Bulb J170 A/C

BULB J170 A/C

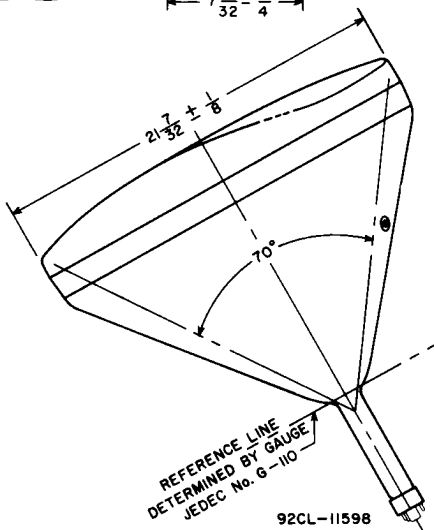
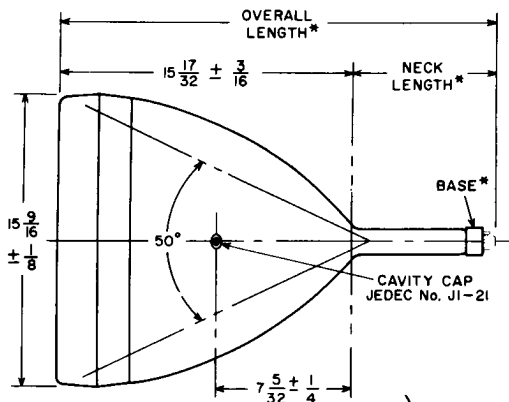

ALL DIMENSIONS IN INCHES

* See data for specific tube type.



RADIO CORPORATION OF AMERICA
Electron Tube Division
Harrison, N. J.

CRT
OUTLINES 15
3-62

Dimensional Outline

FOR PICTURE TUBES UTILIZING

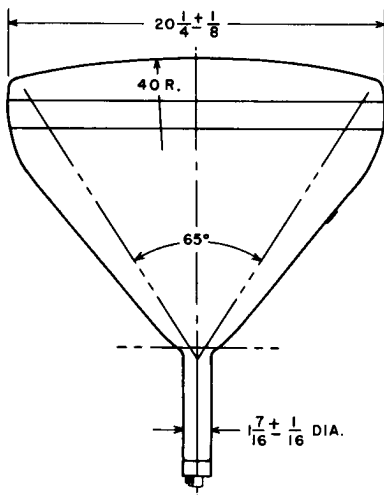
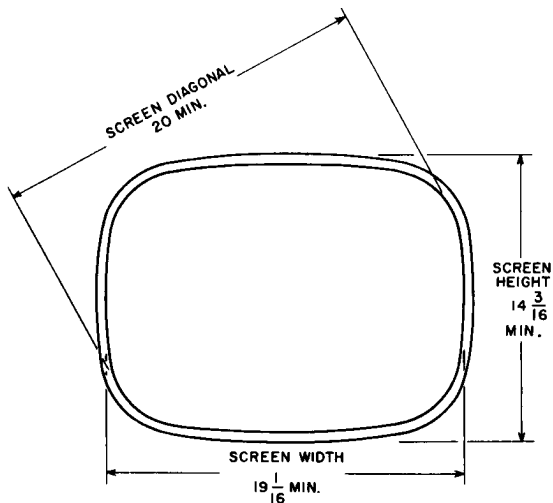

RADIO CORPORATION OF AMERICA
Electron Tube Division

Harrison, N. J.



Bulb J170 B/D

BULB J170 B/D

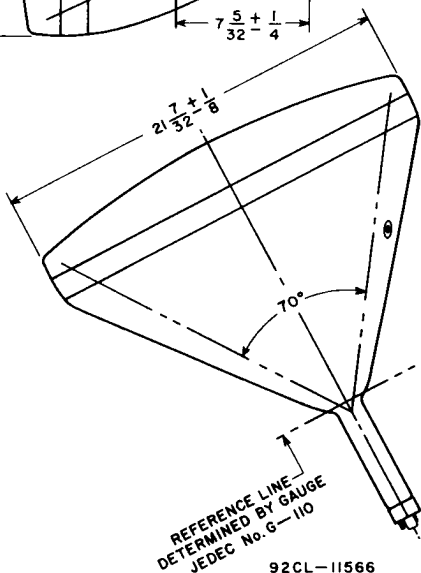
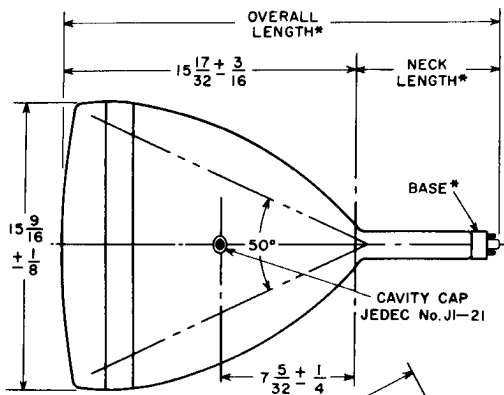

ALL DIMENSIONS IN INCHES

* See data for specific tube type.



RADIO CORPORATION OF AMERICA
Electron Tube Division
Harrison, N. J.

CRT
OUTLINES 16
3-62

Dimensional Outline

FOR PICTURE TUBES UTILIZING

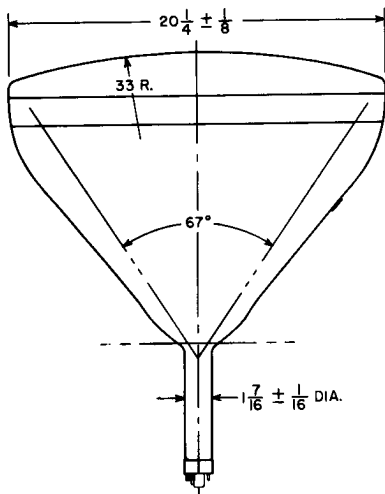
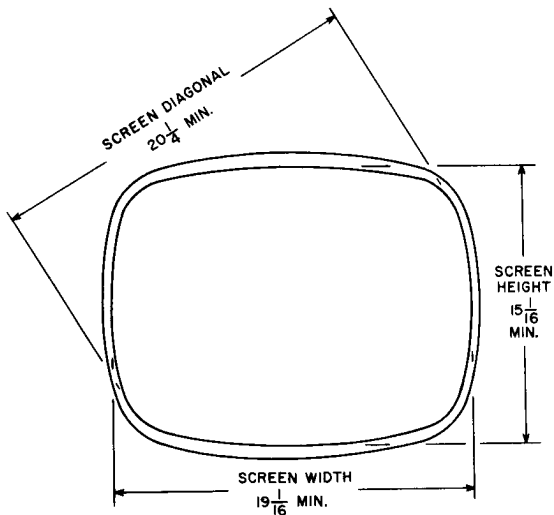

RADIO CORPORATION OF AMERICA
Electron Tube Division

Harrison, N. J.



BULB J171 B/F

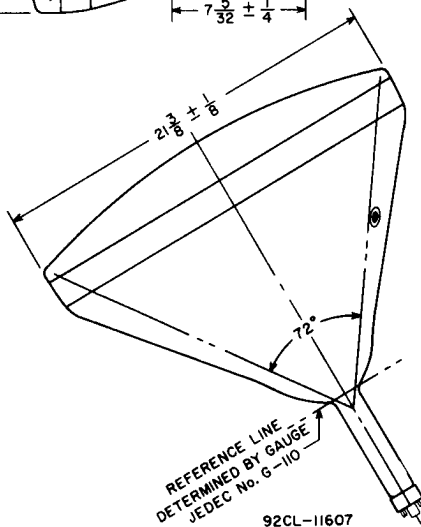
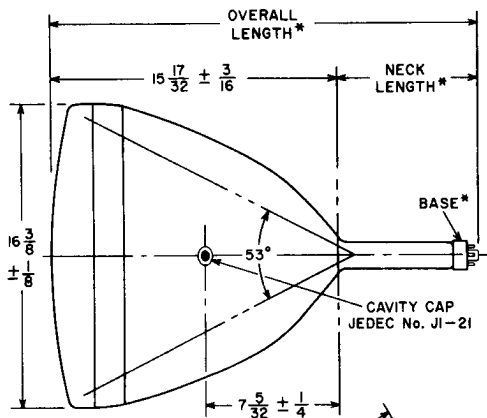

ALL DIMENSIONS IN INCHES

*See data for specific tube type.



RADIO CORPORATION OF AMERICA
Electron Tube Division
Harrison, N. J.

CRT
OUTLINES 17
3-62

Dimensional Outline

FOR PICTURE TUBES UTILIZING

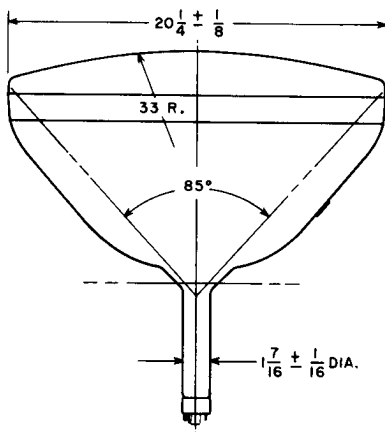
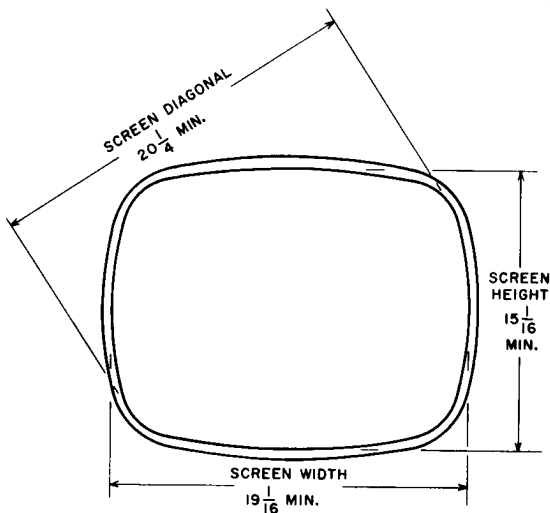

BULB J171 D/E

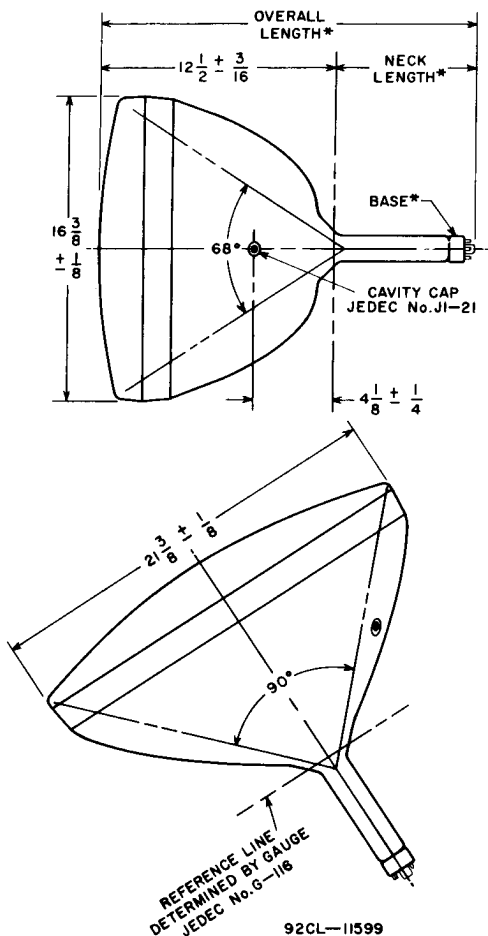

ALL DIMENSIONS IN INCHES

* See data for specific tube type.



RADIO CORPORATION OF AMERICA
Electron Tube Division
Harrison, N. J.

CRT
OUTLINES 18
3-62

Dimensional Outline

FOR PICTURE TUBES UTILIZING

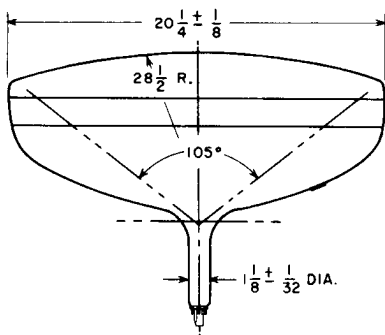
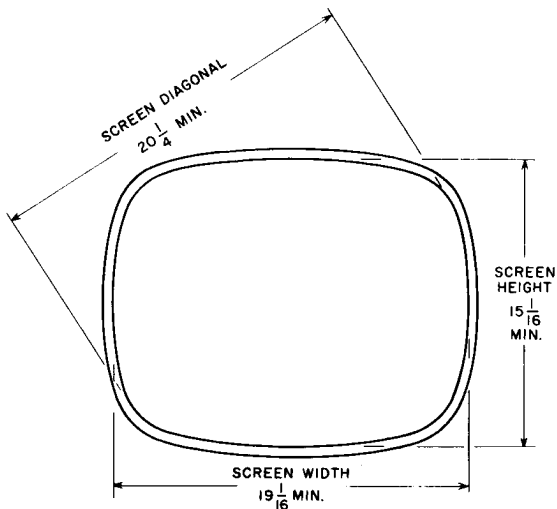

RADIO CORPORATION OF AMERICA
Electron Tube Division

Harrison, N. J.



BULB J171 G/K

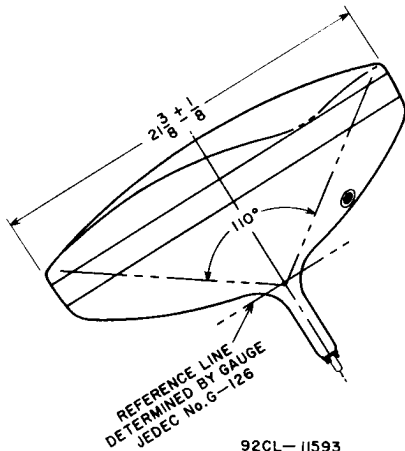
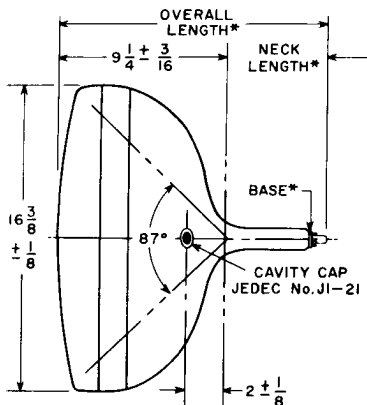

ALL DIMENSIONS IN INCHES

* See data for specific tube type.



RADIO CORPORATION OF AMERICA
Electron Tube Division
Harrison, N. J.

CRT
OUTLINES 19
3-62

Dimensional Outline

FOR PICTURE TUBES UTILIZING

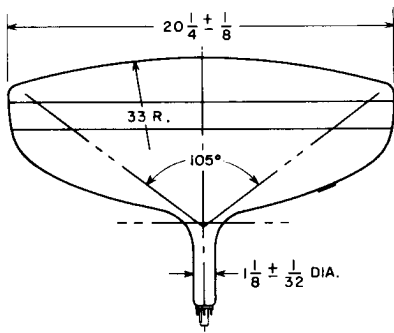
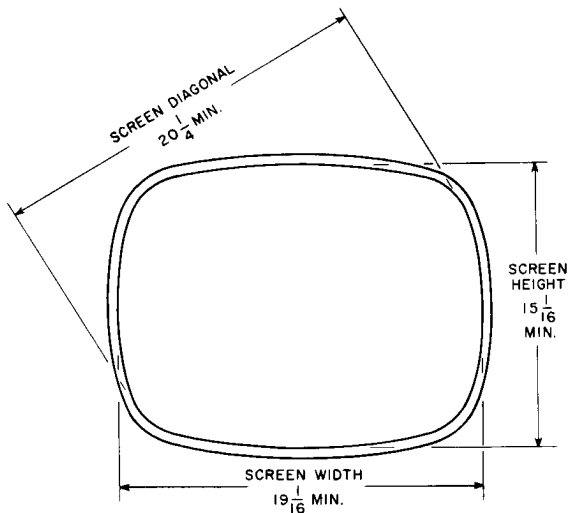

RADIO CORPORATION OF AMERICA
Electron Tube Division

Harrison, N. J.



BULB J171 H/J

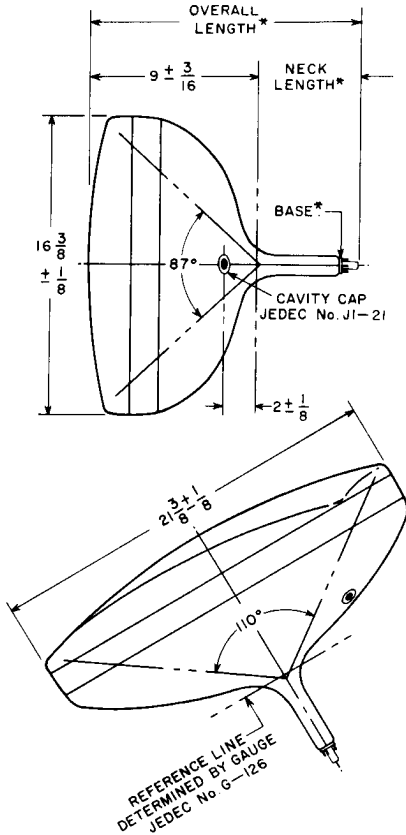

*See data for specific tube type.



RADIO CORPORATION OF AMERICA
Electronic Components and Devices
Harrison, N. J.

CRT
OUTLINES 20
4-65

Dimensional Outline

Bulb J187 A

FOR PICTURE TUBES UTILIZING BULB J187A
AND PROTECTIVE PANEL FP198

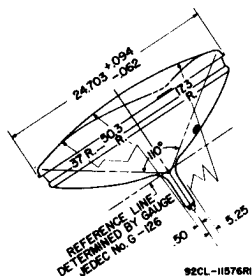
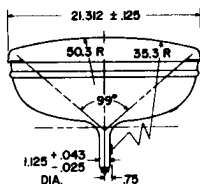
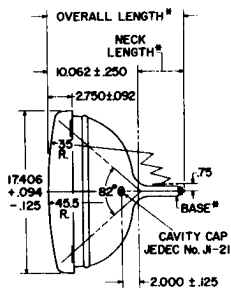
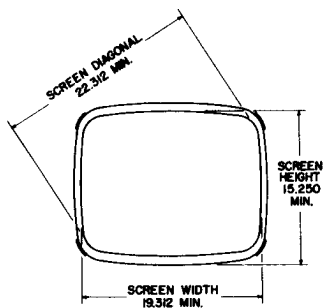

DIMENSIONS IN INCHES

* See data for specific tube type.



FOR PICTURE TUBES UTILIZING BULB J187 B

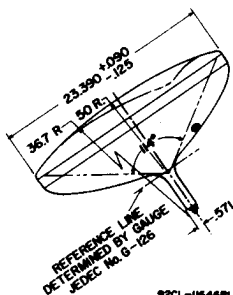
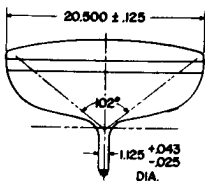
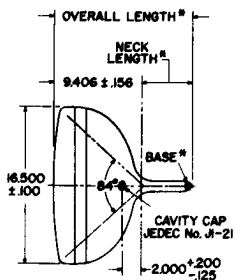
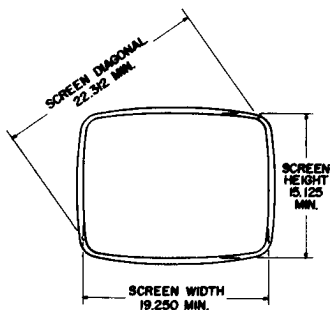

92CL-11646R1

DIMENSIONS IN INCHES

* See data for specific tube type.



Dimensional Outline

FOR PICTURE TUBES UTILIZING BULB J187 C/F

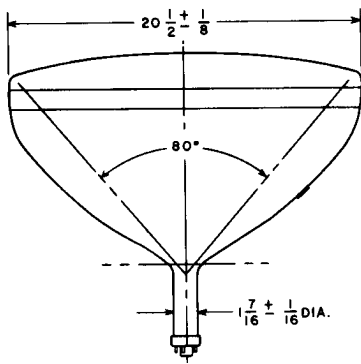
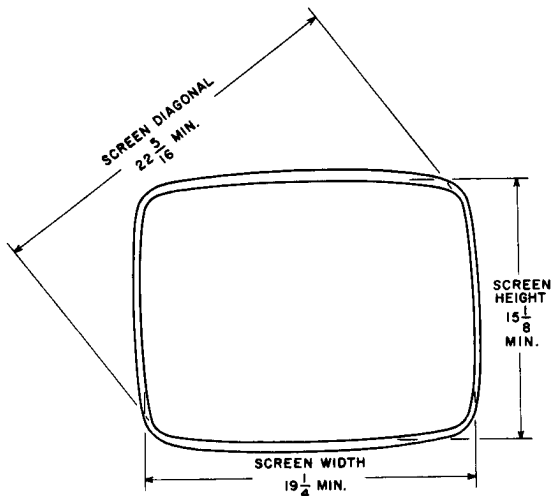

RADIO CORPORATION OF AMERICA
Electronic Components and Devices

Harrison, N. J.



Bulb J187 C/F

BULB J187 C/F

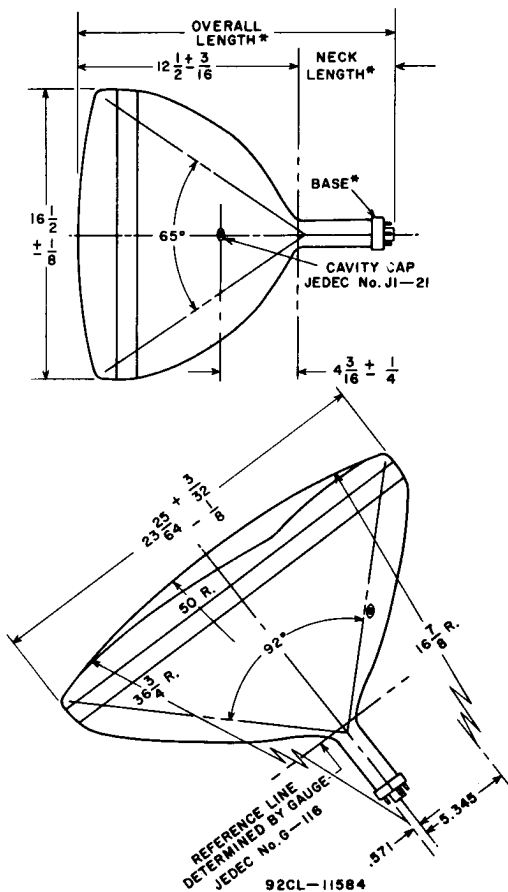

ALL DIMENSIONS IN INCHES

* See data for specific tube type.



RADIO CORPORATION OF AMERICA
Electron Tube Division
Harrison, N. J.

CRT
OUTLINES 23
3-62

Dimensional Outline

FOR PICTURE TUBES UTILIZING

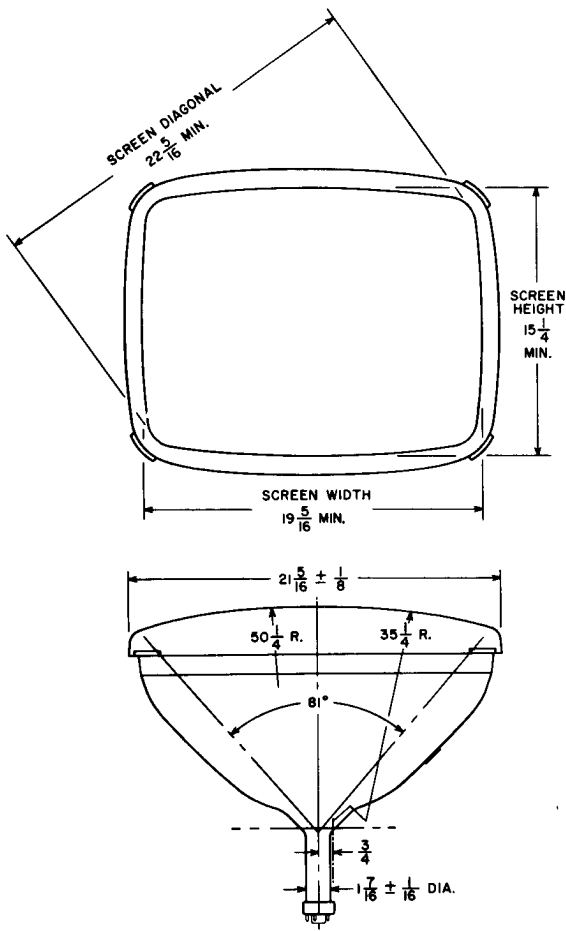

RADIO CORPORATION OF AMERICA
Electron Tube Division

Harrison, N. J.



Bulb J187 D/G

BULB J187 D/G AND PROTECTIVE PANEL

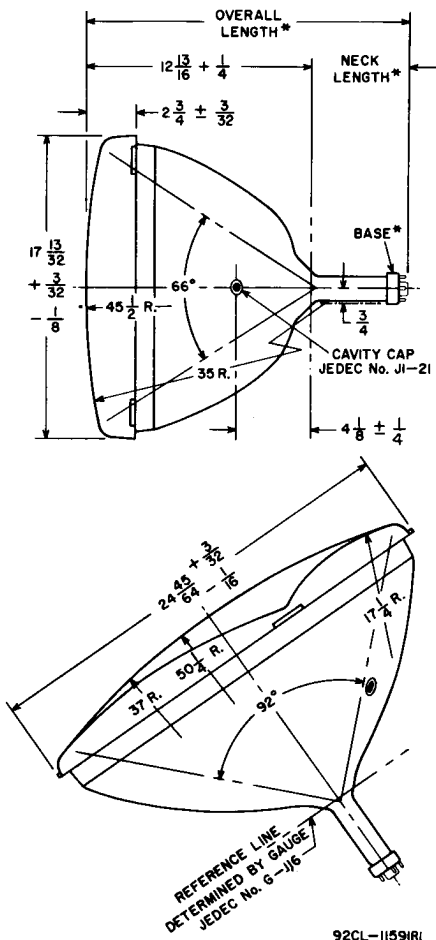

DIMENSIONS IN INCHES

*See data for specific tube type.



RADIO CORPORATION OF AMERICA
 Electronic Components and Devices
 Harrison, N. J.

CRT
 OUTLINES 24
 8-64

Dimensional Outline

Bulb J187 E

FOR PICTURE TUBES UTILIZING BULB J187 E

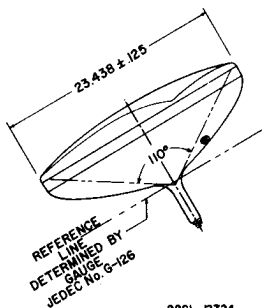
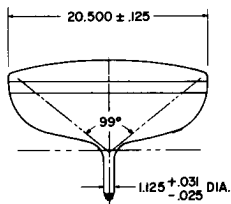
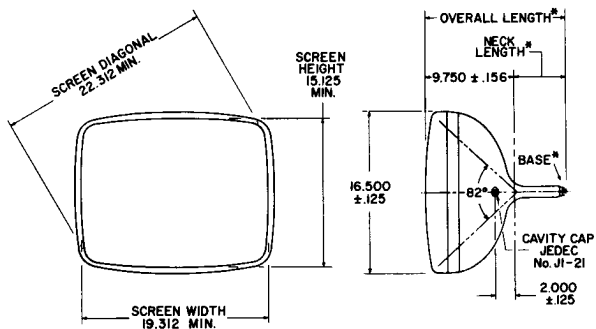

92CL-12724

DIMENSIONS IN INCHES

*See data for specific tube type.

FOR PICTURE TUBES UTILIZING BULB J187 H1

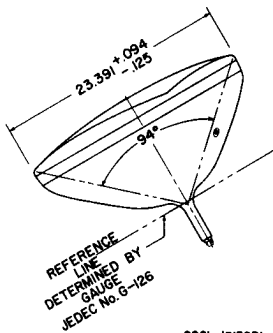
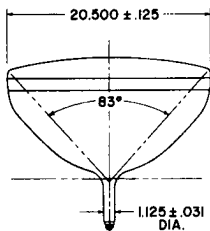
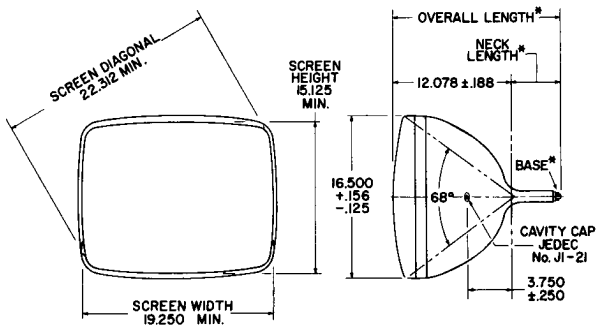

92CL-12139R1

DIMENSIONS IN INCHES

*See data for specific tube type.



Dimensional Outline

Bulb J187 J

FOR PICTURE TUBES UTILIZING BULB J187 J

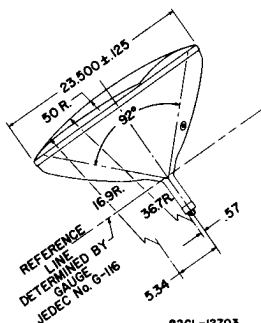
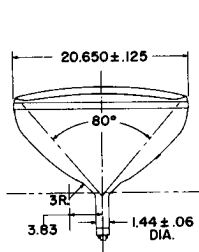
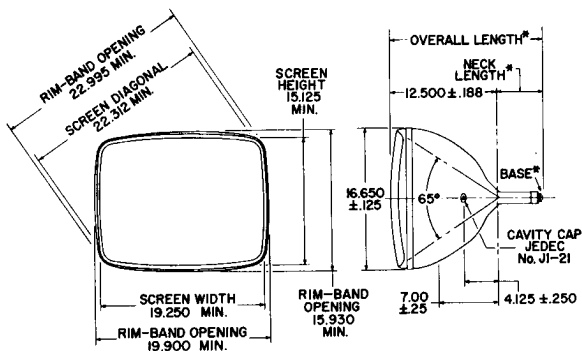

92CL-12703

DIMENSIONS IN INCHES

*See data for specific tube type.

RADIO CORPORATION OF AMERICA
Electronic Components and Devices

Harrison, N. J.



FOR PICTURE TUBES UTILIZING BULB J187 K

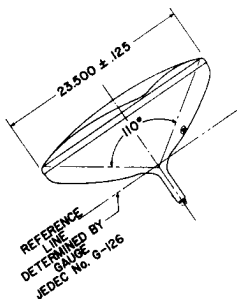
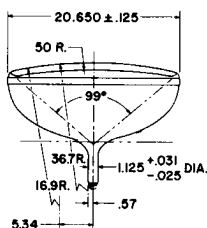
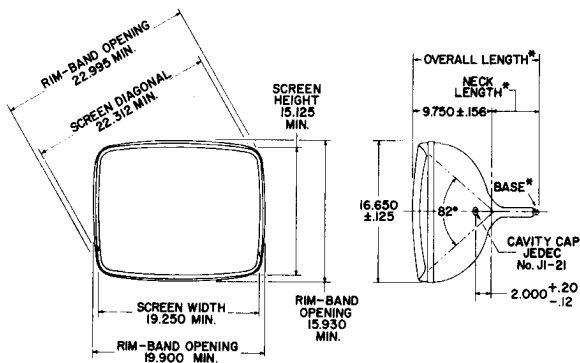

92CL-12702

DIMENSIONS IN INCHES

*See data for specific tube type.



RADIO CORPORATION OF AMERICA
Electronic Components and Devices
Harrison, N. J.

CRT
OUTLINES 26
4-65

Dimensional Outline

Bulb J187 L

FOR PICTURE TUBES UTILIZING BULB J187 L

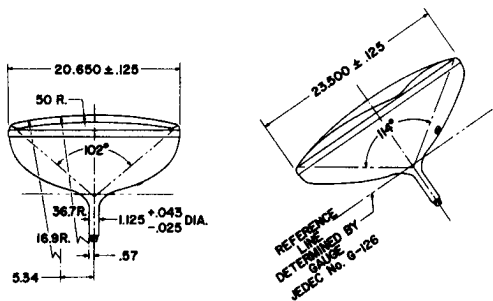
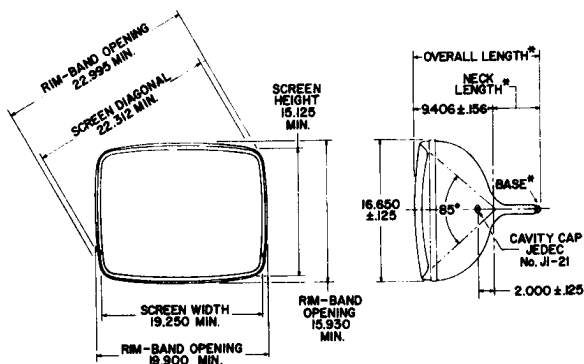

92CL-13019

DIMENSIONS IN INCHES

*See data for specific tube type.



FOR PICTURE TUBES UTILIZING BULB J187 M

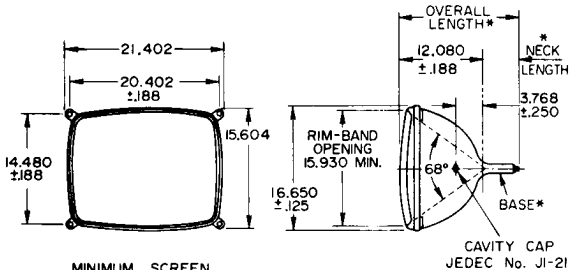

MINIMUM SCREEN

DIAGONAL 22.312
 GREATEST WIDTH 19.250
 GREATEST HEIGHT 15.125

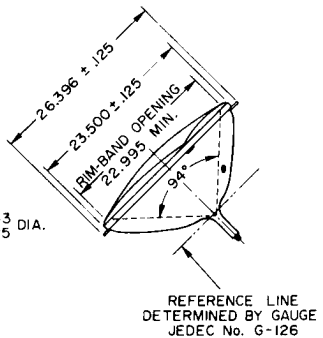
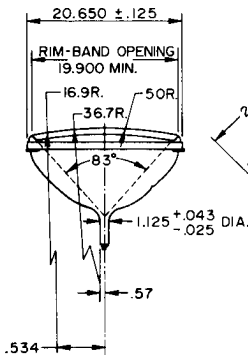

92LM-1477

DIMENSIONS IN INCHES

* See data for specific tube type.



RADIO CORPORATION OF AMERICA
 Electronic Components and Devices
 Harrison, N. J.

CRT
 OUTLINES 26A
 10-66

Dimensional Outline Bulb J192 A/B

FOR PICTURE TUBES UTILIZING BULB J192 A/B

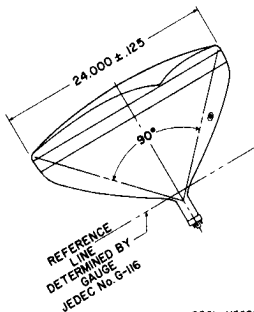
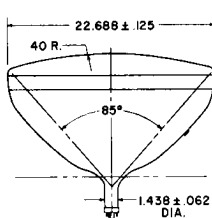
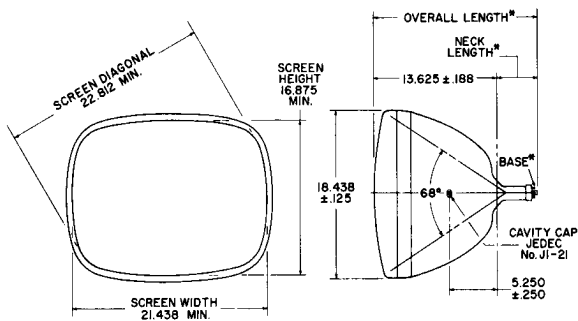

92CL-11583R1

DIMENSIONS IN INCHES

* See data for specific tube type.



Dimensional Outline Bulb J192 C/D

FOR PICTURE TUBES UTILIZING BULB J192 C/D

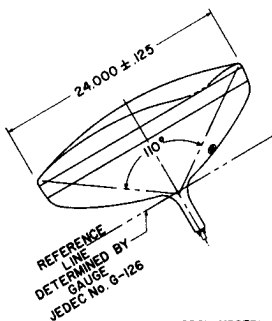
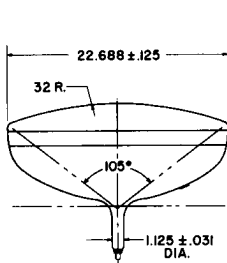
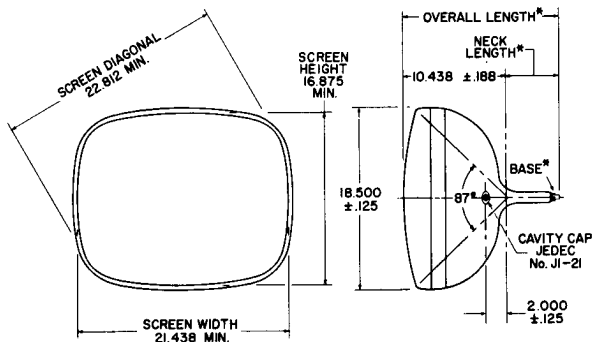

92CL-11587R1

DIMENSIONS IN INCHES

*See data for specific tube type.



RADIO CORPORATION OF AMERICA
Electronic Components and Devices

Harrison, N. J.

CRT
OUTLINES 27
8-64

Dimensional Outline Bulb J214-1/2 A

FOR PICTURE TUBES UTILIZING BULB J214-1/2 A

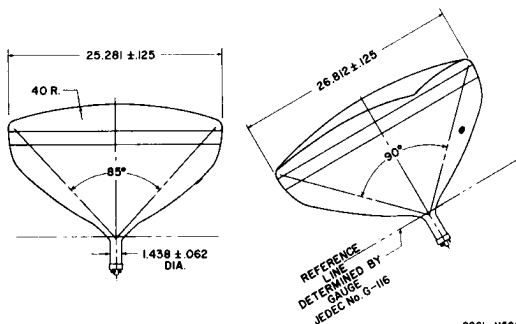
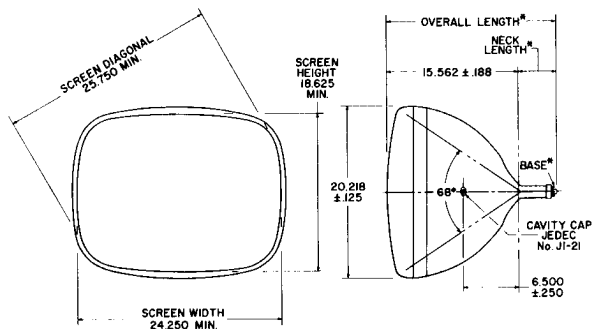

92CL-11586R1

DIMENSIONS IN INCHES

*See data for specific tube type.

RADIO CORPORATION OF AMERICA
Electronic Components and Devices

Harrison, N. J.



Dimensional Outline

Bulb MJ135 A

FOR PICTURE TUBES UTILIZING BULB MJ135 A

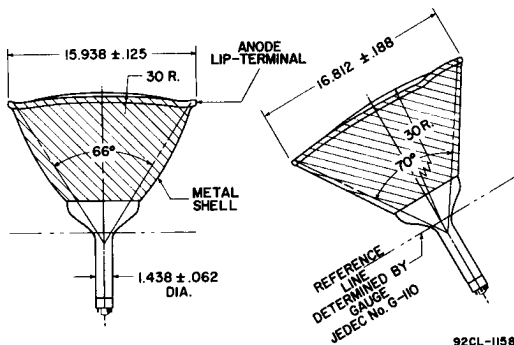
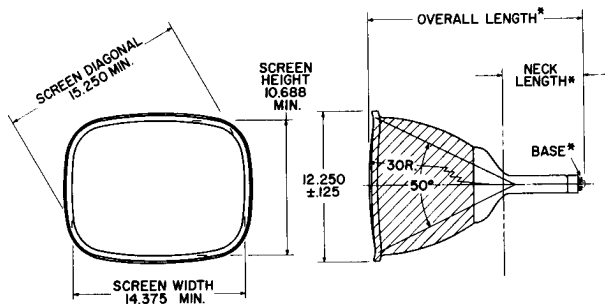

92CL-11588R1

DIMENSIONS IN INCHES

*See data for specific tube type.



RADIO CORPORATION OF AMERICA
Electronic Components and Devices
Harrison, N. J.

CRT
OUTLINES 28
8-64

Dimensional Outline

FOR PICTURE TUBES UTILIZING BULB MJ166 A

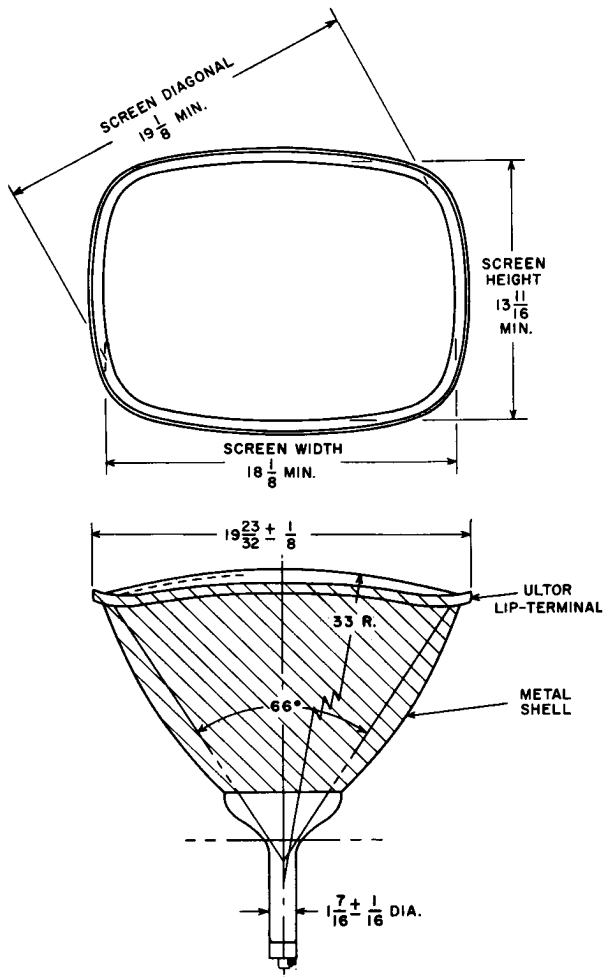

RADIO CORPORATION OF AMERICA
Electronic Components and Devices

Harrison, N. J.



Bulb MJ166 A

BULB MJ166 A

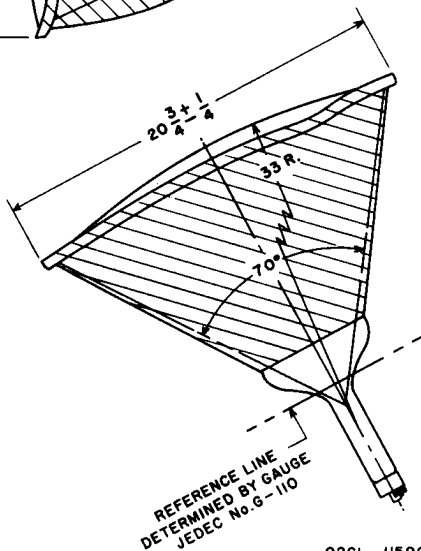
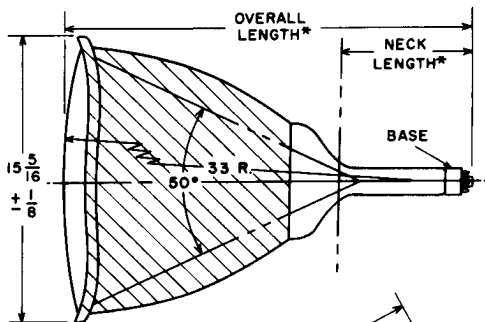

92CL-11590

ALL DIMENSIONS IN INCHES

* See data for specific tube type.



RADIO CORPORATION OF AMERICA
Electron Tube Division
Harrison, N. J.

CRT
OUTLINES 29
3-62

Dimensional Outline

FOR PICTURE TUBES UTILIZING

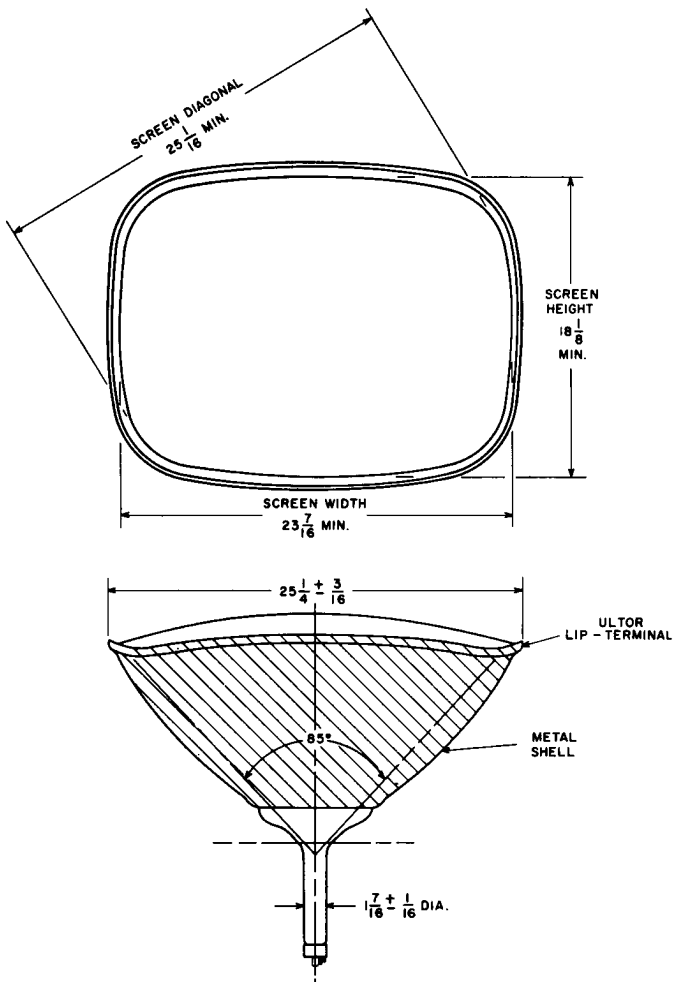

Bulb MJ214 A

BULB MJ214 A

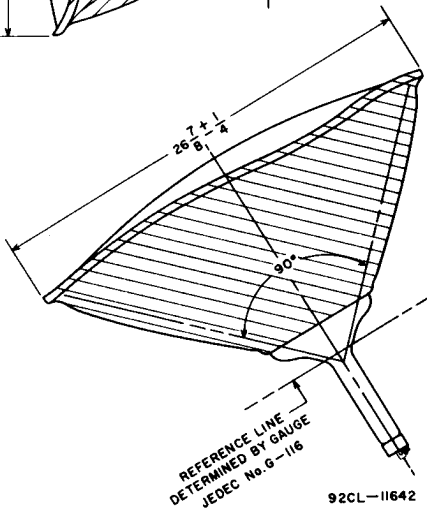
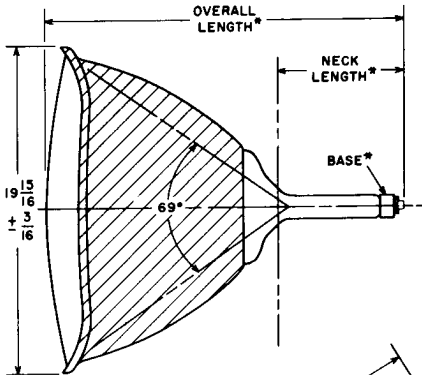

ALL DIMENSIONS IN INCHES

* See data for specific tube type.



RADIO CORPORATION OF AMERICA
Electron Tube Division
Harrison, N. J.

CRT
OUTLINES 30
3-62



REFERENCE-LINE GAUGE JETEC N^o G-110

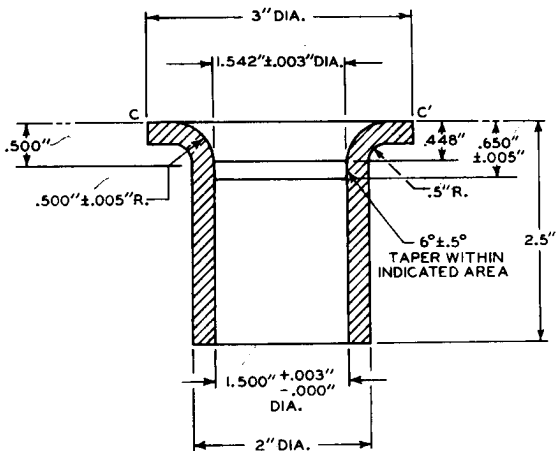

WHEN TUBE NECK IS INSERTED THROUGH GAUGE,
REFERENCE LINE WILL BE DETERMINED BY PLANE
C-C' WHEN GAUGE IS RESTING ON FUNNEL.

92CS-7391R1



REFERENCE-LINE GAUGE JETEC N^oG-116

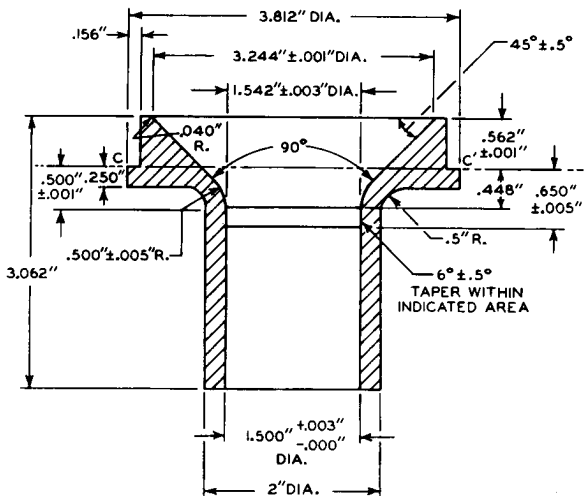

WHEN TUBE NECK IS INSERTED THROUGH GAUGE,
REFERENCE LINE WILL BE DETERMINED BY PLANE
C-C' WHEN GAUGE IS RESTING ON FUNNEL.

92CS-7896R1



REFERENCE-LINE GAUGE JETEC N^oG-126

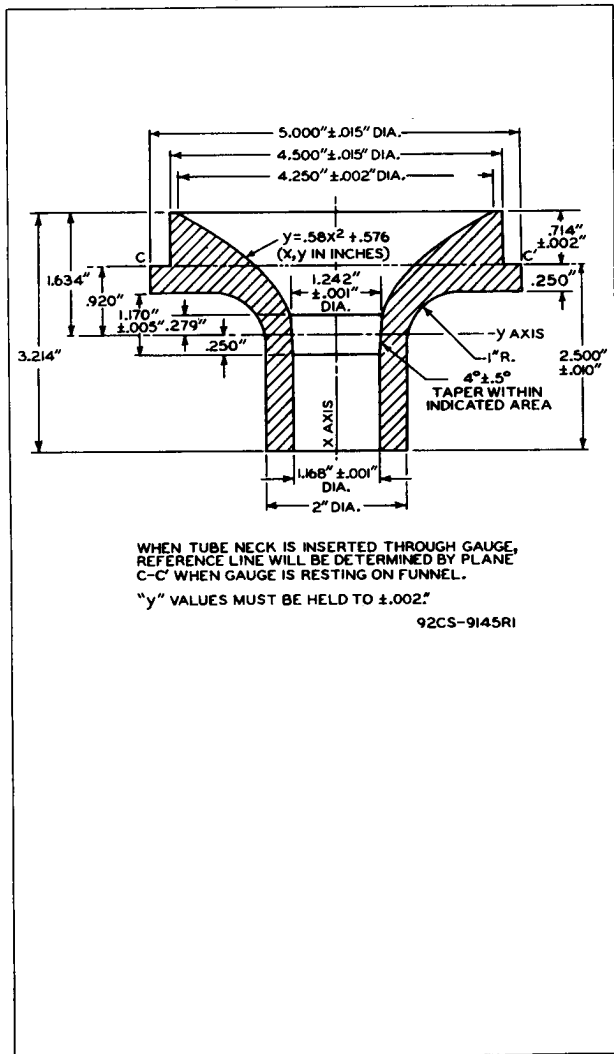

WHEN TUBE NECK IS INSERTED THROUGH GAUGE,
REFERENCE LINE WILL BE DETERMINED BY PLANE
C-C WHEN GAUGE IS RESTING ON FUNNEL.

"y" VALUES MUST BE HELD TO $\pm .002''$.

92CS-9145R1

X-Radiation Precautions

For Cathode-Ray Tubes

WARNING

All types of cathode-ray tubes may be operated at voltages (where ratings permit) up to 16 kilovolts without personal injury on prolonged exposure at close range.

Above 16 kilovolts, special shielding precautions for X radiation may be necessary.



Definitions

Of Cathode-Ray-Tube Terms

Ultor. The "ultor" in a cathode-ray tube is the element to which is applied the highest dc voltage for accelerating the electrons in the beam prior to its deflection.

Post-Ultor. The "post-ultor" in a cathode-ray tube is the element to which is applied a dc voltage higher than the ultor voltage for accelerating the electrons in the beam after its deflection.

