

# —Standard Valves—

3B/100-B  
Valve

## VALVE TYPE 3B/100-B

TRIODE.

### SPECIFICATION.

#### Cathode.

Indirectly heated oxide coated.  
Constant voltage type.

#### Base.

Standard British 5-pin.

#### Dimensions.

Maximum overall length  $4\frac{11}{16}$ " (11.9 cms.)  
Bulb diameter 1.77" (4.5 cms.)  
Net weight 0.11 lbs. (50 gms.)

#### Constants.

Heater voltage 4 volts  
Heater current 1.1 amps.  
\*Amplification factor 13  
\*Impedance 2,000 ohms.  
\*Mutual conductance 6.5 mA per volt  
Grid-anode capacity 7.5  $\mu\mu\text{F}$ .  
Grid-cathode capacity 10.3  $\mu\mu\text{F}$ .  
Anode-cathode capacity 4.8  $\mu\mu\text{F}$ .

\* at  $V_p = 200$   $V_{g1} = -10$  volts.

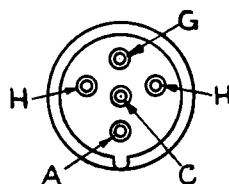
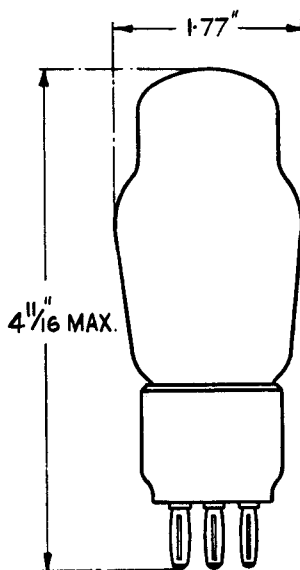

### LIMITING CONDITIONS FOR SAFE OPERATION.

Maximum direct anode voltage	200 volts
Maximum direct anode current	50 mA.
Maximum anode dissipation	10 watts

Tentative Data

W.3B/100-B.1  
Feb. 1939

# —Standard Valves—

## TYPICAL OPERATING CONDITIONS.

Class A. AF Amplifier					
Anode Voltage volts	Grid Bias volts	Anode Current mA.	Load Resistance ohms	Power Output mW.	Total Harmonics db.
100	—4	23	8,000	10	38
100	—4	23	8,000	50	31
150	—6	40	10,000	50	35
150	—6	40	10,000	100	32
200	—10	40	10,000	50	37
200	—10	40	10,000	250	30

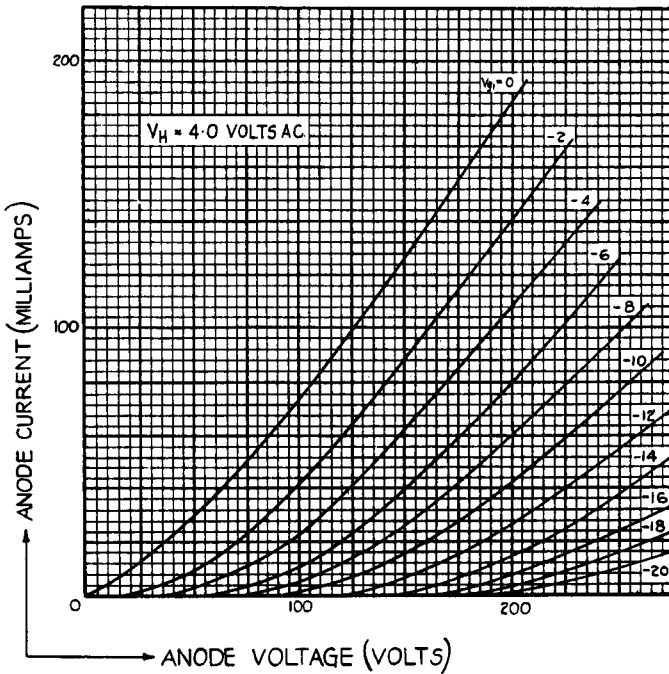

# —Standard Valves—

3B/100-B  
Valve

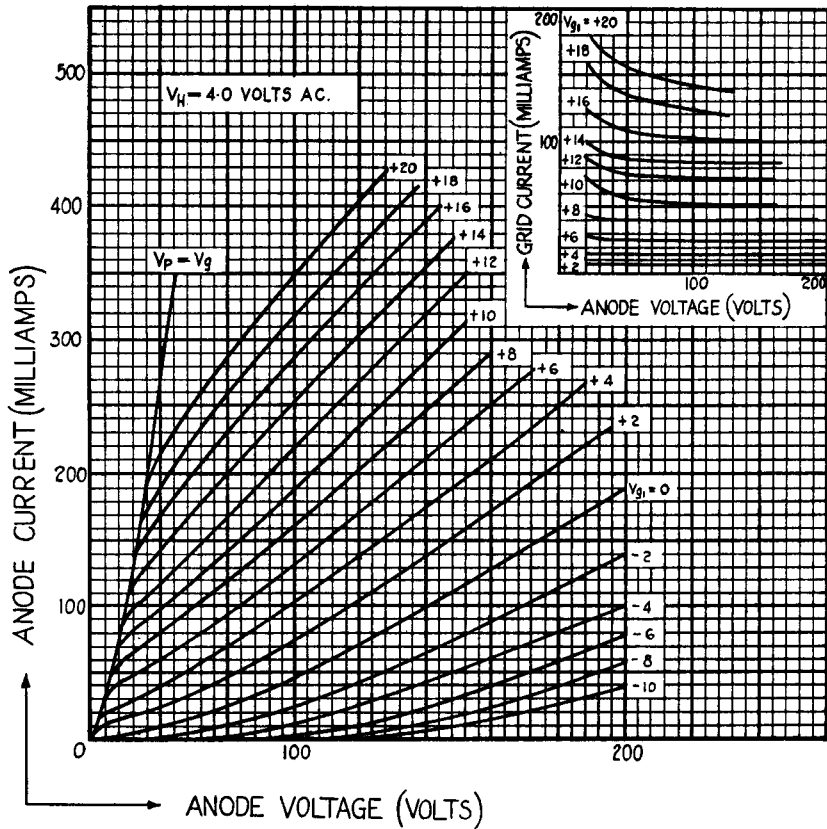

Tentative data  
FY 12

W.3B/100-B.2  
Feb. 1939

PRINTED IN  
ENGLAND