

MECHANICAL DATA

Bulb	T-3
Base	E8-10, Subminiature Button Flexible Leads
Outline	JETEC 3-1
Basing	8DK
Cathode	Coated Unipotential
Mounting Position	Any

RATINGS' (Absolute Values)

Impact Acceleration	450 G
Fatigue (Vibrational Acceleration for Extended Periods)	2.5 G
Bulb Temperature (At Hottest Point)	165° C
Altitude ²	80000 Ft.

ELECTRICAL DATA

HEATER CHARACTERISTICS

Heater Voltage ³	6.3 V
Heater Current	150 mA
Heater Power	0.95 W

DIRECT INTERELECTRODE CAPACITANCES

	Shielded ⁴	Unshielded
Grid to Plate	1.3	1.4 $\mu\mu\text{f}$
Input	2.4	2.2 $\mu\mu\text{f}$
Output	2.4	0.7 $\mu\mu\text{f}$

RATINGS^{1, 5 & 6} (Absolute Maximum)

Plate Voltage	165 Vdc
Peak Plate Forward Voltage ⁷	600 v
Plate Dissipation	2.2 W
DC Grid Voltage	
Positive	5.5 Vdc
Negative	5.5 Vdc
Peak Grid Voltage	
Positive	27.5 v
Negative	220 v
Average Positive Grid Current	5.5 mAdc
Peak Positive Grid Current	110 mA
Heater-Cathode Voltage	
Heater Positive with Respect to Cathode ⁸	
Total DC and Peak	200 v
DC	100 Vdc
Heater Negative with Respect to Cathode	
Total DC and Peak	200 v
Grid Circuit Resistance	1.0 Meg

AVERAGE CHARACTERISTICS

Plate Voltage	100 Vdc
Grid Voltage	0 Vdc
Cathode Resistor	150 Ohms
Plate Current	10 mAdc
Transconductance	6000 μmhos
Amplification Factor	29
Plate Resistance	4800 Ohms
Plate Current at Conditions Ebb = 125 Vdc; Ecc = +3 Vdc; Rp = 2700 Ohms; Rg = 60000 Ohms	15.5 mAdc
Cutoff with Ebb = 140 Vdc; Rp = 2700 Ohms; Rg = 60000 Ohms; Grid Supply Voltage for Ib = 100 μAdc	-8.5 Vdc Max.

QUICK REFERENCE DATA

The Premium Subminiature Type 6814 is a sharp cutoff, medium mu triode intended primarily for application in electronic computers. The tube is characterized by high zero bias plate current and exceptional freedom from the development of cathode interface.

The 6814 is designed to provide dependable service under severe conditions of shock, vibration, high temperature and high altitude.

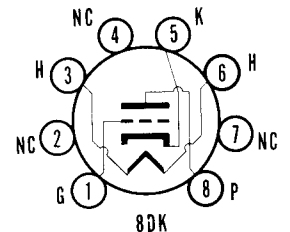
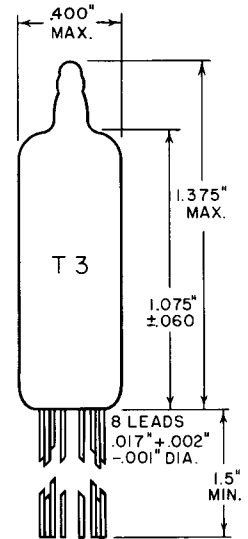

SYLVANIA ELECTRIC PRODUCTS INC.

**RADIO TUBE DIVISION
EMPORIUM, PA.**

*Prepared and Released By The
TECHNICAL PUBLICATIONS SECTION
EMPORIUM, PENNSYLVANIA*

FEBRUARY 1957

PAGE 1 OF 8

AVERAGE CHARACTERISTICS (Continued)

Interelectrode Resistance		
Plate to All at 300 Vdc; Ef = 6.3 V	10 Meg Min.
Grid to All at 100 Vdc; Ef = 6.3 V	10 Meg Min.
Cathode Positive so that no Cathode Emission Occurs	

TIME DEPENDENT CHARACTERISTICS

Minimum Number of Heater Cycles	2500
Regulation of Heater Supply	3 Percent Max.
Ef = 7.0 Vac	
Ehk = 140 Vac	

NOTES:

1. Limitations beyond which normal tube performance and tube life may be impaired.
2. If altitude rating is exceeded, reduction of instantaneous voltages (Ef excluded) may be required.
3. Tube life and reliability of performance are directly related to the degree of regulation of the heater voltage to its center rated value of 6.3 volts.
4. External shield of 0.405 inch diameter connected to cathode.
5. Values shown are as registered with RETMA.
6. The ratings of peak characteristics apply to a square topped pulse of 1000 cps frequency and 1.0% duty factor.
7. Per MIL-E-1C Par. 6.5 and General Section of the Sylvania Subminiature Tube Manual titled Specifications and Ratings.
8. Heater Positive not recommended for reliable operation.

ACCEPTANCE CRITERIA

Test Conditions

Heater Voltage	6.3 V	Heater-Cathode Voltage	0 V
Plate Voltage	100 Vdc	Cathode Resistor MIL-E-1 Par. 3.2.2.1	150 Ohms
Grid Voltage	0 V			

For the purposes of inspection, use applicable reliable paragraphs of MIL-E-1 and Inspection Instructions for Electron Tubes.

MIL-E-1 Ref.	Test	AQL (%)	Limits					Units
			Min.	LAL	Bogey	UAL	Max.	
Measurements Acceptance Tests, Part I, Note 1								
4.10.8	Heater Current:	0.65	138	—	—	—	162	mA
4.10.15	Heater-Cathode Leakage:	0.65	—	—	—	—	—	μAdc
	Ehk = +100 Vdc.....	—	—	—	—	—	5.0	
	Ehk = -100 Vdc.....	—	—	—	—	—	5.0	
4.10.6.1	Grid Current: Eb = 150 Vdc; Rk = 220 Ohms, Rg = 1.0 Meg.....	0.65	0	—	—	—	-0.4	μAdc
4.10.4.1	Plate Current (1): Ebb = 125 Vdc; Ecc = +3 Vdc; Rp = 2700 Ohms; Rg = 0.06 Meg.....	0.65	14	—	15.5	—	—	mAdc
4.10.5.2	Grid Voltage: Ebb = 140 Vdc; Rp = 2700 Ohms; Rg = 0.06 Meg; Adj Ecc for Ib = 100 μa.....	0.65	—	—	—	—	8.5	Vdc
---	Continuity and Shorts (Inoperatives): Note 2.....	1.0	—	—	—	—	—	
4.9.1	Mechanical: Envelope (8-1).....	—	—	—	—	—	—	

ACCEPTANCE CRITERIA (Continued)

MIL-E-1 Ref.	Test	AQL (%)	Limits					Units
			Min.	LAL	Bogey	UAL	Max.	
Measurements Acceptance Tests, Part 2								
4.8.2	Insulation of Electrodes:..... g-all = 100 V..... p-all = 300 V.....	2.5 — —	— 50 50	— — —	— — —	— — —	— — —	Meg Meg
4.10.4.1	Plate Current (2): Ef = 5.7 V; Ebb = 125 Vdc; Ecc = +3 Vdc; Rp = 2700 Ohms; Rg = 0.06 Meg.....	2.5	13	—	—	—	—	mAdc
4.10.6.2	Grid Emission: Note 5 Ef = 7.5 V; Rg = 1.0 Meg; Rk = 0 Ohms; Ec = -8.5 Vdc..	2.5	0	—	—	—	-0.5	μAdc
4.10.9	Transconductance: Sm.....	2.5	5000	—	6000	—	7000	μmhos
4.10.11.1	Amplification Factor:.....	6.5	25	—	—	29	33	
4.10.4.1	Plate Current (3):.....	6.5	7.5	—	10	—	12.5	mAdc
4.10.14	Capacitance:..... No Shield Cgp..... No Shield Cin..... No Shield Cout.....	6.5 — — —	— 1.1 1.6 0.5	— — — —	— 1.4 2.2 0.7	— — — —	— 1.8 2.8 0.9	μμf μμf μμf
4.9.12.1	Low Pressure Voltage Breakdown: Pressure = 20 ± 5 mm Hg.; Voltage = 300 Vac.....	6.5	—	—	—	—	—	
4.9.19.1	Vibration: F = 40 cps; G = 15; Rp = 10,000 Ohms; Ck = 1000 μf.....	2.5	—	—	—	—	50	mVac
Degradation Rate Acceptance Tests, Note 3								
4.9.5.3	Subminiature Lead Fatigue:.....	2.5	4	—	—	—	—	arcs
4.9.20.5	Shock: Hammer Angle = 30°.....	20	—	—	—	—	—	
4.9.20.6	Fatigue: G = 2.5; Fixed Frequency; F = 25 min., 60 max.....	6.5	—	—	—	—	—	
— — — —	Post Shock and Fatigue Test End Points:							
	Vibration.....	—	—	—	—	—	200	mVac
	Heater-Cathode Leakage							
	Ehk = +100 Vdc.....	—	—	—	—	—	15	μAdc
	Ehk = -100 Vdc.....	—	—	—	—	—	15	μAdc
	Plate Current (1).....	—	13	—	—	—	—	mAdc
	Grid Voltage.....	—	—	—	—	—	-8.5	Vdc
4.9.6.3	Glass Strain:.....	6.5	—	—	—	—	—	

MIL-E-1 Ref.	Test	AQL (%)	Allowable Defectives per Characteristic		Limits		Units
			1st Sample	Combined Samples	Min.	Max.	
Acceptance Life Tests, Note 3							
4.11.7	Heater Cycling Life Test: Ef = 7.0 V; 1 min. on, 4 min. off; Ehk = 140 Vac; Ec = Eb = 0 V.....	2.5	—	—	—	—	
4.11.5	Intermittent Life Test: Note 4						
4.11.3.1	Eb = 150 Vdc; Rk = 220 Ohms; Rg1 = 1.0 Meg; T Envelope = +165°C min.; Ehk = +200 Vdc.....	—	—	—	—	—	

ACCEPTANCE CRITERIA (Continued)

MIL-E-1 Ref.	Test	AQL (%)	Allowable Defectives per Characteristic		Limits		Units
			1st Sample	Combined Samples	Min.	Max.	
Acceptance Life Tests, Note 3 (Continued)							
4.11.3.1 4.11.4	Intermittent Life Test End Points: (500 Hours)						
	Inoperatives.....	—	1	3	—	—	mAdc
	Plate Current (1).....	—	1	3	13	—	Vdc
	Grid Voltage.....	—	1	3	—	-8.5	Vdc
	Grid Current.....	—	1	3	0	-0.6	μAdc
	Heater-Cathode Leakage.....	—	2	5	—	—	—
	Ehk = +100 Vdc.....	—	—	—	—	10	μAdc
	Ehk = -100 Vdc.....	—	—	—	—	10	μAdc
	Heater Current.....	—	2	5	136	166	mA
	Insulation of Electrodes.....	—	2	5	—	—	—
	g1-all.....	—	—	—	10	—	Meg
	p-all.....	—	—	—	10	—	Meg
	Total Defectives.....	—	4	8	—	—	—
Information Life Test, Note 6							
-----	Interface Impedance Evaluation Life Test: Ef = 7.0 V; Eb = Ec = 0 V; Continuous Operation for 500 Hours.....	—	—	—	—	—	—
-----	Evaluation Life Test End Points: (500 Hours) Note 7 Interface Impedance Zi.....	—	—	—	—	50	Ohms

ACCEPTANCE CRITERIA NOTES:

- 1: The AQL for the combined defectives for attributes in Measurements Acceptance Tests, Part 1, excluding inoperatives and mechanical shall be one (1) percent. A tube having one (1) or more defects shall be counted as one (1) defective.
- 2: All tubes shall be tested for continuity of all circuits, including duplicate pin connections to the same electrode; for shorts between any of the tube elements or between the elements and the no-connection base pins; and for air leaks.

Testing for shorts shall be performed using the Sylvania Automatic Tapper, B5-1379-A6. Each tube shall be tapped a total of six taps, three in each of two planes 90° apart. The tapper shall be adjusted so that the peak acceleration level delivered to the tube is 75 G's as measured with a Gulton A-305 accelerometer and KA-1 kit. The shorts detecting equipment shall be a dc device capable of detecting as shorts the following interelement resistances of the given time durations.

Interelement Resistance	Time Duration
4.5 megohms or less	80 μsec or greater
2.2 megohms or less	27 μsec or greater
1.0 megohm or less	14 μsec or greater
0.1 megohm or less	4.5 μsec or greater
10,000 ohms or less	2.5 μsec or greater

Continuity testing shall be performed with tapping of the tube as specified in MIL-E-1 Par. 4.7.5.

Tubes which give indication of one or more of the following shall be rejected without retesting.

- (a) Any short during tapping
- (b) Any open circuit
- (c) Air leaks (defined in 5.3.6.1, Inspection Instructions for Electron Tubes).

- 3: Tubes subjected to the following destructive tests are not to be accepted under this specification.

- 4.9.5.3 Subminiature lead fatigue
- 4.9.20.5 Shock
- 4.9.20.6 Fatigue
- 4.11.7 Heater cycling life test
- 4.11.5 Intermittent life test

- 4: Envelope temperature is defined as the highest temperature indicated when using a thermocouple of #40 BS or smaller diameter elements welded to a ring of 0.025 inch diameter phosphor bronze placed in contact with the bulb. Envelope temperature requirement will be satisfied if a tube, having bogey Ib (±5%) under normal test conditions, is determined to operate at maximum specified temperature at any position on the life rack.

- 5: Prior to this test, tubes shall be preheated five (5) minutes at conditions indicated below. Test within three (3) seconds after preheating. Three-minute test is not permitted. Grid Emission shall be the last test performed on the sample selected for the Grid Emission Test.

Ef	Eb	Ec	Rk	Rg
V	Vdc	Vdc	Ohms	Meg
7.5	150	0	220	1.0

- 6: This life test shall be conducted on a minimum of one sample of ten tubes each month of production. Operate the life test tubes continuously. Read at 500 hours for information only.

- 7: Interface impedance measurements shall be made in accordance with Method B, the Frost Method, of ASTM Standard F300-55T, "Interface Impedance Characteristics of Vacuum Tube Cathodes". Preheat tubes to be tested for three minutes with Ef = 6.3 V the only applied voltages every time interface impedance test is to be performed. Test with conditions Ef = 6.3 V; Eb = 100 Vdc; Ec/Ib = 1.0 mAdc; Esig = 0.2 V peak to peak square wave at 50 kc.

APPLICATION DATA

The Sylvania Premium Subminiature Type 6814 is a sharp cutoff, medium mu triode having high zero bias plate current. The Type 6814 is characterized by extremely tight controls on cutoff and zero bias plate current, making it especially well suited for multivibrator and/or frequency divider service in electronic computers. The Type 6814 also exhibits exceptional freedom from the development of cathode interface after long periods under off conditions, and freedom from momentary shorts. The heater-cathode construction is designed to provide dependable service under conditions of intermittent operation.

The Type 6814 is designed for long life and stable operation under conditions of severe shock, vibration, high altitude and high temperature and is manufactured

and inspected to meet the applicable specification for reliability.

Life expectancy is described by the life tests specified on the attached pages and/or individual specification. The actual life expectancy of the tubes in an operating circuit is affected by both the operating and environmental conditions involved. Likewise, the life tests specified indicate performance under certain operating criteria to a set of specified end points. Performance at conditions other than those specified can usually be estimated only roughly as giving better or poorer life expectancy. For further discussion of life expectancy, reference should be made to the frontal section of this manual.

RESISTANCE COUPLED AMPLIFIER DATA

	Ebb = 100 Volts						Ebb = 250 Volts					
	.047		0.10		0.27		.047		0.10		0.27	
Rb (megohms).....												
Rcf (megohms).....	0.1	0.27	0.27	0.47	0.27	0.47	0.1	0.27	0.27	0.47	0.27	0.47
Rk (ohms).....	1500	1800	3300	3900	8200	10000	1000	1200	2200	2700	5600	6800
Ib (ma).....	1.13	1.06	0.57	0.53	0.24	0.22	3.20	2.98	1.57	1.46	0.63	0.59
Ec (volts).....	-1.69	-1.91	-1.88	-2.06	-1.93	-2.18	-3.20	-3.58	-3.45	-3.94	-3.53	-4.0
Eb (volts).....	45.5	48	41	45	34	39	97	103	90	100	76	87
Esig (volts, rms).....	0.5	0.5	0.5	0.5	0.5	0.5	1.0	1.0	1.0	1.0	1.0	1.0
Eout (volts, rms).....	9.0	9.15	9.1	9.1	8.45	8.7	20.4	20.8	20.4	20.3	18.5	19.4
Gain.....	18.0	18.3	18.2	18.2	16.9	17.4	20.4	20.8	20.4	20.3	18.5	19.4
% Distortion.....	3.7	2.8	2.6	2.2	2.9	2.0	2.3	1.9	2.0	1.6	2.2	1.4
Esig* (volts, rms).....	0.66	0.80	0.85	0.95	0.75	1.00	1.85	2.15	2.07	2.42	1.90	2.44
Eout (volts, rms).....	11.8	14.5	15.5	17.3	12.5	17.4	37.0	44.0	42.2	49.0	35.1	47
Gain.....	17.9	18.1	18.2	18.2	16.8	17.4	20.0	20.5	20.4	20.2	18.4	19.2
% Distortion.....	5.0	5.0	5.0	5.0	5.0	4.8	4.85	4.9	5.0	5.0	5.0	5.0

*Maximum signal for 5% distortion or 1/8 microampere grid current.

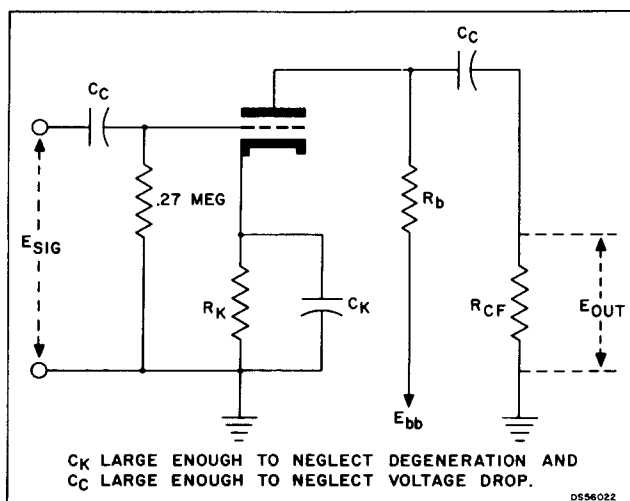

Resistance coupled amplifier circuit

The information presented on this data sheet is furnished without assuming any obligation.

AVERAGE TRANSFER CHARACTERISTICS

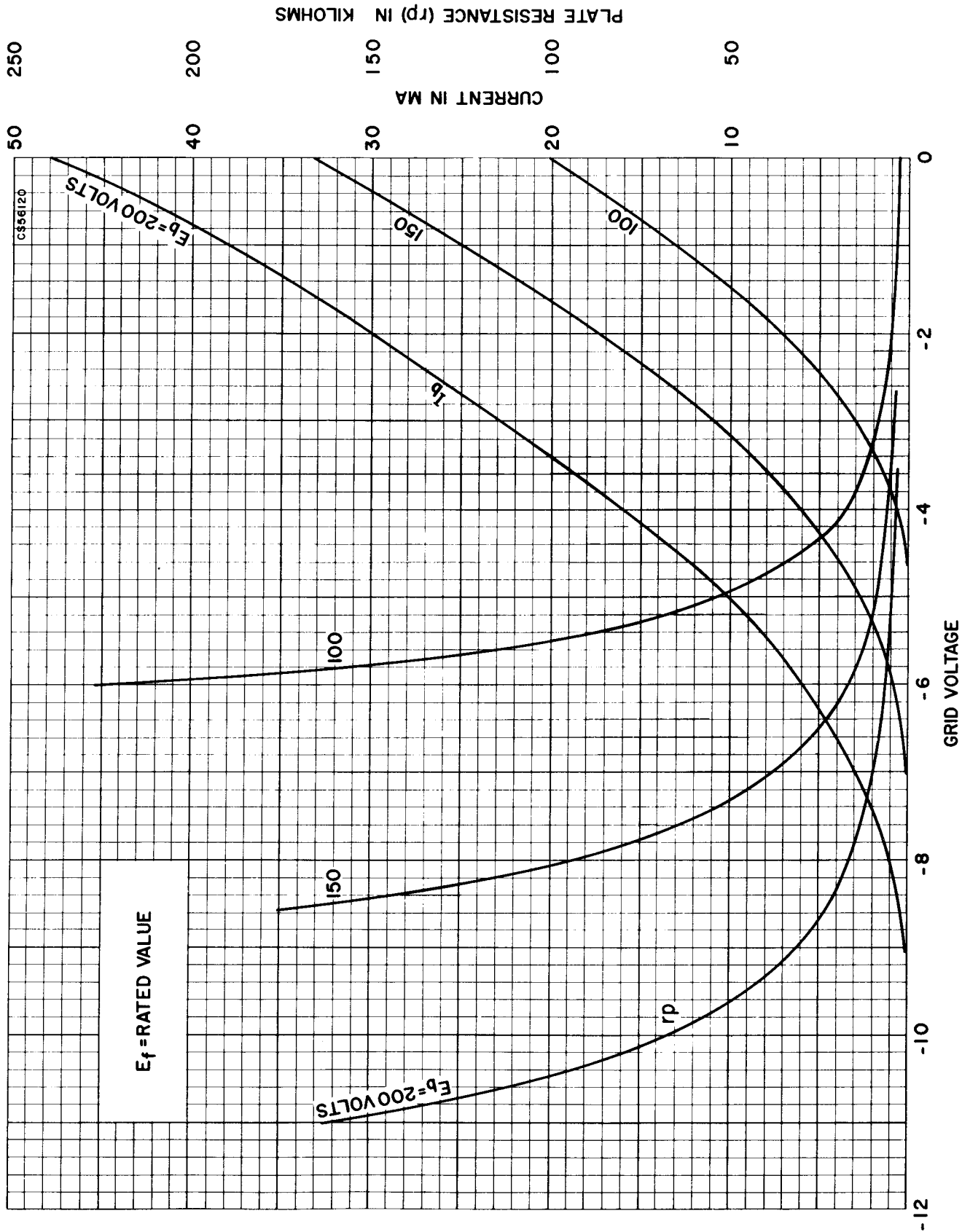

AVERAGE TRANSFER CHARACTERISTICS

